



CASE
CONSTRUCTION

E-SERIES CRAWLER EXCAVATORS



CX210E

HERITAGE

A TRADITION OF INDUSTRY FIRSTS



1842

CASE is founded.

1869

The first CASE portable steam engine - road construction is born.

1957

The first factory - integrated loader/backhoe in the world: a CASE industry first.

1969

CASE begins skid steer loader production.

1977

CASE acquires Poclain, a French brand leader in the excavators market.

1992

Sumitomo becomes supplier to CASE Corporation distributing excavators ranging from 7 to 80 tons.

1998

Global Alliance signed between CASE Corporation and Sumitomo.

2001

CASE introduces the first of its CX excavators, powerful new "thinking machines" designed to enhance productivity through onboard intelligence features.

2007

CX210B is awarded the «Good Design Award» by the design Academy of Japan.

2008

CX210B wins the 18th «Energy Conservation Award» from the Agency for Natural Resources and Energy of the Japanese Ministry of Economy.

2011

CASE becomes the first construction equipment manufacturer to offer both selective catalytic reduction and cooled exhaust gas recirculation as solutions to meet stringent emissions standards.

2015

CASE launches the new "D-Series" Tier 4 final / EU Stage IV Crawler Excavators.

2018

Stage V production for models CX350D and above, followed by Short Radius models.

2021

CASE introduces the first models of Stage V E-Series Crawler Excavators, featuring new FPT engine, new monitor, enhanced hydraulics and improved connected services.

CRAWLER EXCAVATORS

E-ENHANCED GENERATION

ENHANCED QUALITY AND RELIABILITY

Stronger than ever, built to last

- + The reinforced clamp improves the pipe holding force on the boom.
- + The shape and thickness of the inner reinforcement plate thickness increases the boom's durability.
- + The tolerance of the boom and arm cylinder pins has been updated to reduce clatter and play within the bushing.
- + A new stop valve adjustment mechanism has been added for easier piping-valve connection.
- + The more compact assembly of the undercarriage recoil spring and grease cylinder facilitates clearing the mud.
- + The CX210E and CX250E feature a new, more efficient and durable travel motor, while the upgraded travel motor on the CX300E delivers higher drawbar pull.
- + The upper carrier rollers [on CX160E / CX180E / CX210E / CX250E] have been upgraded for greater durability.
- + The shoe bolt size [on CX300E] has been increased.

ENHANCED PRECISION AND CONTROLLABILITY

Smooth control, efficient operation – more than ever

The trademark **CASE Intelligent Hydraulic System (CIHS)** is now paired with new work modes and adjustable hydraulic settings to deliver the smoother and more efficient operation than the previous generation.



E-SERIES

CRAWLER EXCAVATORS

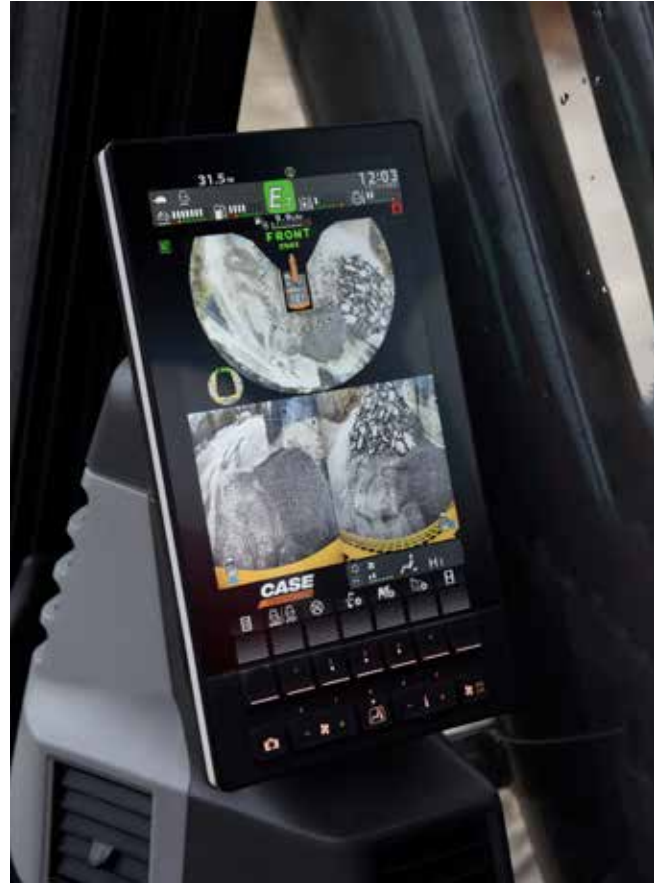

ENHANCED VERSATILITY

A high degree of customization for every task

The new-concept work modes with independent throttle position offer a precise match to the requirements of every task:

SP (Super Power) mode for maximum productivity (as in D-Series) with the throttle set at maximum power.

P (Power) mode replaces H and A mode in D-Series, with throttle settings from 1 to 10.

E (Eco) mode for maximum fuel economy, with throttle settings from 1 to 10.

L (Lifting) mode is optimized for object handling with power boost permanently activated and overload warning system, and throttle settings from 1 to 6.

The choice of available work modes can be locked by the machine owner.

NEW The ground-breaking Eco mode reduces fuel consumption through selective control of engine and pump depending on the movement. It maintains maximum pump torque to deliver high productivity, while minimizing fuel consumption during low effort operations.



The balance of the hydraulic flows can also be customized to suit the operator's preferences:

- + “Arm In” vs “Boom Up”
- + “Arm In” vs “Swing” [only from CX210E upward]

The E-Series takes versatility even further by enabling the operator to select the type of work tool and input the customizable model number on the machine's monitor. When selecting the flow and pressure settings, they can also set the maximum overflow to protect the attachment.

A new, optional +500 kg **additional counterweight** is available on the CX210E LC to ensure perfect stability also with heavier quick couplers and attachments, further extending the machine's capacity to adapt to different work conditions.



PRODUCTIVITY

WORK SMART, PRODUCE MORE

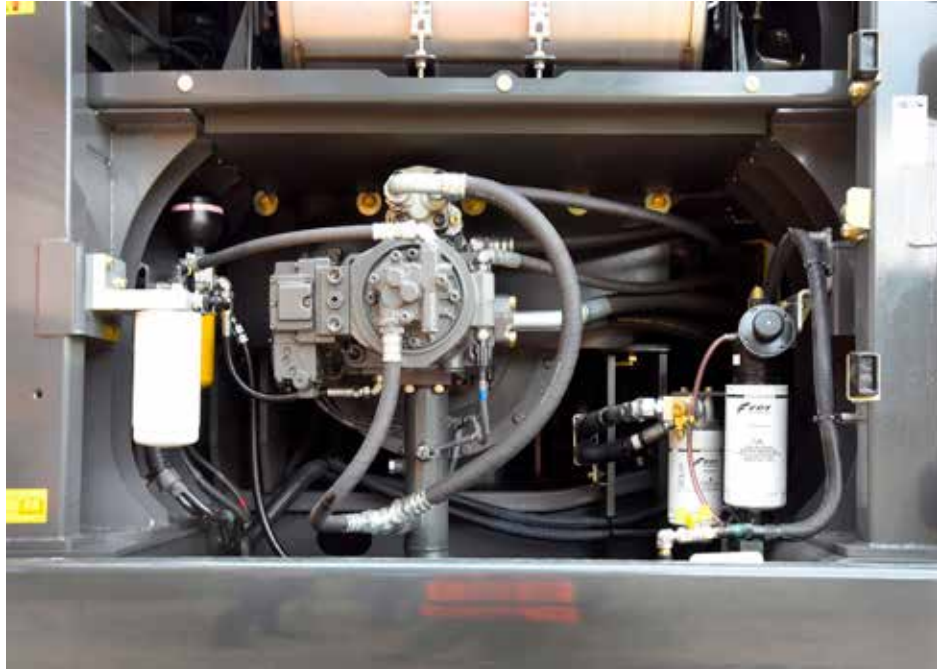

ENHANCED EFFICIENCY

Top performance, high fuel economy

The new-generation E-Series combines the proven energy saving features of the D-Series with new work modes and hydraulic settings to raise the bar on efficiency.

The advanced automatic energy management system inherited from the D-Series consists of six key energy control functionalities:

- + **Pump Torque Control:** prevents drops in engine speed due to overtorque in high load operations the system while reducing fuel consumption in operations where maximum pump power is not required.
- + **Boom Economy Control:** increases fuel efficiency during boom down and swing movements.
- + **Swing Relief Control:** reduces the initial pump flow while improving control at the start of swing movements to lower fuel consumption.
- + **Spool Stroke Control:** automatically adjusts pressure based on the sensors' feedback, avoiding unnecessary functionality.
- + **Boom Oil Regeneration:** the returning oil from boom down is used to speed up the arm out movement [only from CX210E upward].
- + **Auto Idle / Idle Shutdown:** customizable and manually switchable functions that lower engine rpms after a period of inactivity or shut down the engine after a period of idling.

With all these features, coordinated by the CASE Intelligent Hydraulic System, together with the new FPT engine and improved travel motor for additional mechanical efficiency, the E-Series excavators deliver unprecedented performance and high fuel economy.



CLEANER POWER

EU Stage V compliant engines



The new FPT NEF engines meet Stage V standards with the innovative HI-eSCR2 solution developed in-house, which only uses a Diesel Oxidation Catalyst and an integrated **maintenance-free** device on the SCR catalyst to achieve this dramatic reduction in emissions.

- + The SCR-on-Filter is “built-for-life” and requires no replacement or mechanical cleaning for its entire guaranteed emission regulation life.
- + The air intake flow is increased by a turbocharger with air-to-air cooling.
- + The multiple injection delivers best-in-class high torque performance at low rpms.
- + **No EGR** valve means 100% fresh air is used for combustion and no extra cooling system is required.

The new Stage V NEF engines can take their low-emission performance even further, as they can operate on **B7 biodiesel** and **HVO** (an even cleaner and more high-quality alternative to biodiesel, with superior performances in cold weathers) and other paraffinic fuels like **GTL** (Gas-to-Liquids), **CTL** (Coal-to-Liquids), **BTL** (Biomass-to-Liquids).

COMFORT RULES

FIRST-CLASS WORK ENVIRONMENT



ENHANCED COMFORT

Ideal working conditions, every day

- + Pressurized cab with improved sealing, wide access space and increased foot space.
- + Ergonomic air-suspended high-back seat with tilt adjustment and optional heater.
- + Console suspended with the seat and optimized control lever positions: the operator maintains their preferred working posture when adjusting the seat's position.
- + Reduced pedal travel and footrest reduce fatigue during operation.
- + Automatic air conditioning controls integrated in the monitor.
- + Air conditioning performance improved with a cooling upgrade and optimal air vents location.
- + Optimized storage capacity with lunch box tray and cool box, smartphone tray, and two large drink holders.
- + Repositioned lower track rollers reduce vibrations for smoother travelling.
- + Quieter cab with 1 dB lower internal noise compared to D-Series on CX210E, and 3 dB lower on CX250E / CX300E.



SAFETY AND MAINTENANCE

WORK SAFELY IN ALL CONDITIONS

SAFER OPERATION AND ACCESSIBILITY

Safety first, inside and outside the cab

- + Reinforced cab structure ROPS and FOPS compliant.
- + Standard FOPS level 2 head protection.
- + Factory fitted front guard OPG level 2; grill guard and front guard OPG level 1 available as DIA kits.
- + Optional factory fitted travel alarm for greater safety on the jobsite around the machine.
- + New auto lever lock safety feature immediately stops machine movement when the operator unintentionally unlocks the gate lock.
- + Seat belt fastened detection.
- + Wide, robust and comfortable steps, and handrail for safe access to the top of the hood.
- + Non-slip plates and top hood cover supported by two gas pistons and secured by two mechanical stops.
- + Wide platform on top of the engine compartment to work safely on the engine box.

SUPERIOR VISIBILITY

Designed for outstanding visibility

Visibility – already outstanding in the D-Series - has been further enhanced:

- + Glazed surface with improved visibility on the right hand side.
- + Bigger monitor (from 7 to 10”) with higher resolution, five configurable buttons and additional menus on the display.
- + Standard rear- and right-hand cameras, and an optional left-hand camera is available for the 270° CASE Maximum View Monitor with revised screen layout.
- + Upgraded cameras for better color balance.
- + Improved front window defrost.
- + New diffusion spray type window washer nozzle ensures better windshield cleaning.
- + Optional LED lights package available for brighter and wider illumination.
- + “Follow me” lights function with selectable off timer.



SAFETY AND MAINTENANCE

WORK SAFELY IN ALL CONDITIONS



EASY MAINTENANCE

“Grounded” and connected services solution

- + New extended service intervals for lower maintenance costs:
 - **Engine oil, fuel & oil filters** extended from 500 to 1,000 hours;
 - **AdBlue supply module filter** was 3,000 hours, it goes up to 4,000 hours;
 - **Travel gear oil** extended from 1,000 to 2,000 hours (on CX210E / CX250E).
- + Extended Maintenance System (EMS) bushings provide 1,000 hour greasing intervals on arm and boom pins and 250 hours on the attachment pin.
- + No EGR reduces complexity in the ATS.
- + SCR-on-Filter auto-cleaning device requires no replacement or mechanical cleaning during guaranteed life span.
- + Fuel nozzle with integrated fuel tank float provides better visibility during refilling.
- + Hydraulic oil tank cap with integrated air breather for tool-less refill.
- + Newly added sampling valve in pump room for easier hydraulic oil sampling.
- + Increased washer tank capacity for fewer washer refills.
- + Grease cylinder compact design for easier mud cleaning around carrier rollers.
- + Two-piece split cab floor mat for simpler cleaning.
- + Radiator shroud with larger opening from the side and additional opening below the upper structure for better accessibility (added opening only on CX210E / CX250E).
- + Air cleaner height change for easier put on and off.



- + A/C condenser tilt movement added to facilitate cleaning.
- + New reversible fan option (available for CX210E / CX250E).
- + Fan belt auto-tensioner requires no manual calibration.
- + Remote diagnostics and assistance, and interactive maintenance with the new bidirectional CASE SiteConnect module and enhanced SiteWatch telematics services.
- + The new aftermarket offering of CASE **NEXPRO rubber bolt-on pads**, available on CX210E fitted with 600mm shoes, makes it easy and quick to switch between on- and off-road applications, extending the machine's versatility and improving the customer's profitability.
- + The CX210E will also benefit from a new aftermarket offering of dedicated service maintenance kits, helping the customers to further improve their TCO.



MAIN REASONS TO CHOOSE THE NEW E-SERIES

BEST MATCH BETWEEN SPEED AND CONTROLLABILITY

CASE Intelligent Hydraulics System (CIHS) is synonymous and reference in the market for its fastest cycles times, best energy saving performance and smooth control.

ENHANCED QUALITY AND RELIABILITY

CASE excavators are known for their balanced design and first-class components. New improvements to arm, boom and undercarriage structure make them even better.

ENHANCED VERSATILITY

- + **NEW** 4 work modes
(Super Power, Power, Eco, Lifting)
- + **NEW** 10 throttle settings, independent from work mode
- + **NEW** arm, boom and swing flow balance customization to suit every application
- + **NEW** attachment types and names storable in the display for quicker tools management
- + **NEW** optional heavier +500kg counterweight for CX210E LC to handle heavier attachments

ENHANCED EFFICIENCY

- + **NEW** Eco mode ensures the best selective engine and pump control, maximizing torque only when needed and saving more fuel
- + **NEW** FPT Stage V engine with no EGR, more efficient combustion
- + **NEW** upgraded travel motor for improved mechanical efficiency

ENHANCED CONNECTIVITY

- + **NEW** bidirectional CASE SiteConnect module
- + **NEW** interactive maintenance capabilities
- + **NEW** remote assistance
- + **NEW** standard CASE full telematics solution (modem, wiring, harnesses, antenna and 3-year advanced SiteWatch subscription)

SUPERIOR VISIBILITY

- + **NEW** 10" LCD monitor – the biggest in the industry – with 5 configurable buttons and new menu functions
- + **NEW** front window defrost and washing improvement
- + **NEW** greater visibility on the right hand side
- + Optional CASE Maximum View Monitor for optimized all-around visibility
- + Optional LED lighting



ENHANCED COMFORT

- + **NEW** console suspended with seat
- + **NEW** wide access space and increased foot space
- + **NEW** dedicated A/C controls in the monitor, always within easy reach
- + **NEW** improved air conditioning with new air vents
- + **NEW** smoother travelling with repositioned rollers
- + **NEW** quieter environment in the cab

EASY MAINTENANCE

- + **NEW** extended 1,000-hour engine oil, fuel & oil filters change interval + 1,000-hour bushing greasing intervals for arm and boom pins
- + **NEW** SCR-on-Filter auto-cleaning device – maintenance-free and built-for-life
- + **NEW** easy access to hydraulic tank thanks to cap with air breather
- + **NEW** split type floor mat
- + **NEW** optional reversible fan for improved radiator cleaning efficiency
- + **NEW** NEXPRO bolt-on rubber pads aftermarket offering for fast replacement and greater versatility
- + **NEW** service maintenance kits aftermarket offering for reduced TCO

CLEANER POWER

- + **NEW** STAGE V engine by FPT, the European leader, known for its reliability and innovative tradition, with more than 25 years' experience
- + **NEW** High Efficiency SCR 2 system, covered by 13 patents
- + **NEW** EGR-free
- + **NEW** compatible with HVO and synthetic alternative fuels

SAFER OPERATION AND ACCESSIBILITY

- + ROPS cab with FOPS level 2
- + Standard extended handrails and guardrails
- + Optional factory fitted travel alarm
- + **NEW** auto lever lock safety feature





THE SCIENCE BIT

The CASE SiteWatch telematics system uses a high-tech control unit mounted on each machine to collate information from that machine and from GPS satellites. This data is then sent wirelessly through the mobile communication networks to the CASE Telematics Web Portal.



SITELWATCH: CENTRALISED FLEET CONTROL BENEFITS AT YOUR FINGERTIPS

Measure your true asset availability and optimise it

- + Eliminate the “phantom fleet”: SiteWatch allows to identify spare units or under loaded machines on each site.
- + Become able to reallocate units where they are more needed.
- + Forward maintenance planning is easier since the actualised working hours are always available.
- + Extend the benefits of SiteWatch to the rest of your fleet: SiteWatch can be installed on the units of other brands as well.

Challenge your Total Cost of Ownership!

- + Being able to compare the fuel usage of different machine types will allow you choose the right equipment.
- + Save on transport costs with planned and grouped maintenance tasks.
- + Peace of mind, optimised uptime and lower repair costs: with preventive maintenance you can for example be alerted if the engine needs to be serviced and avoid disruptive breakdown.
- + Be able to compare your asset Return on Investment on different sites.
- + Your equipment is used only during working hours. You can set up alerts so that you know if it is in use during the weekend or at night.
- + Integrate with the programmed maintenance package, which ensures the required services are performed at the right time.

More safety, lower insurance premium

- + Keep thieves away: dissuade them from attacking your asset because it is geo-localised. SiteWatch is hidden so that thieves can't find it quickly.
- + Your fleet is used only where you decide. You can define a virtual fence and receive an email when a machine exits that perimeter.

CASE EXPERT SUPPORT

ALWAYS WITH YOU

SITECONNECT: PROACTIVE SUPPORT AND REMOTE ASSISTANCE

The SiteConnect module allows to establish a 2-way communication between your machine and your CASE Dealer. They will be able to run remote diagnostics and analyze the machine data before travelling to the unit.

Maximize your machine's uptime

- + Save time as your dealer conducts remote assistance to the operator. The machine can be anywhere while the dealer remotely connects with the machine to do diagnostics.
- + The dealer is supporting you with SiteConnect tools to maximize the uptime for your machine

Optimize service efficiency

- + By enabling your dealer to investigate your asset remotely, allows them to resolve issues in the shortest possible time, in a single visit, with the correct parts and tools.
- + Electronic control units installed on the machine may be subject to software updates: With the SiteConnect module your CASE Dealer will be able to do software updates on your machine remotely
- + Increase uptime, reduce costs!

Lower your Total Cost of Ownership

- + Thanks to the data collected about your machine condition and performance by Siteconnect, your CASE dealer can provide a quick and effective service, when you need it. This gives you increased Uptime.



Download the SiteManager app to enable remote access to your equipment directly from Dealer facilities, always under your permission. A sticker with a SiteConnect QR code is placed on the right cab pillar. Scan the QR code with your mobile device to quickly access the SiteConnect page, where you can easily download the SiteManager App and get more useful contents.

STANDARD AND OPTIONS

STANDARD EQUIPMENT

ENGINE

- + FPT NEF 6-cylinder turbo-charged diesel
- + Stage V
- + Selective Catalytic Reduction on Filter (SCRoF)
- + Diesel Oxidation Catalyst (DOC)
- + EGR-free
- + VGT turbocharger
- + Electronic fuel injection
- + High pressure common rail system
- + Neutral safety start
- + Auto engine warm up, emergency stop
- + Glow-plug pre-heat
- + EPF (Engine Protection Feature)
- + Dual-stage fuel filtration
- + Dual element air filter
- + Remote oil filter
- + Green plug oil drain
- + 1,000 hour engine oil and fuel filters change interval
- + 24-volt system
- + Battery disconnect switch
- + High ambient temperature cooling package
- + External fuel and AdBlue gauges
- + Fuel cooler
- + Fuel filter + fuel prefilter with water accumulation indicator
- + Fuel shut-off valve
- + Idle start
- + Radiator, oil cooler, intercooler – protective screen
- + Refueling pump

FUEL ECONOMY SYSTEMS

- + Eco mode
- + Auto idle
- + One-touch idle
- + Idle shutdown
- + Pump Torque Control (PTC)
- + Boom Economy Control (BEC)
- + Swing Relief Control (SRF)
- + Spool Stroke Control (SSC)
- + Boom Oil Regeneration (BOR)

OPTIONAL EQUIPMENT

ENGINE

- + Engine oil and hydraulic oil sample port
- + Engine precleaner cyclonic self-cleaning type
- + Reversible fan

HYDRAULICS

- + Clamshell circuit
- + Low-flow circuit, proportional control [n.a. on CX210E Long Reach]
- + Single acting hammer circuit with electrical proportional control
- + Multifunction (hammer/high flow) circuit with electrical proportional control [n.a. on CX210E Long Reach]
- + Double acting circuit with electrical proportional control [only on CX210E Long Reach]

HYDRAULICS

- + Hydraulic flow control balance
- + Electronically controlled hydraulic pumps
- + Auto power boost
- + Auto travel speed change
- + 4 selectable work modes
- + Overload warning device
- + ISO pattern controls
- + Pre-set auxiliary pump settings
- + Switch controlled auxiliary selection
- + Auxiliary valve
- + Hydraulic filter restriction indicator
- + Oil cooler
- + 5,000 hour hydraulic oil change interval
- + 2,000 hour hydraulic filter change interval
- + Hydraulic quick coupler provision
- + Hydraulic fluid supply port with air breather

UPPERSTRUCTURE

- + ISO mirrors
- + Handrail – RH access
- + ISO guard rails
- + Isolation mounted cab (fluid and spring)
- + Lifting eyes for counterweight
- + Lockable fuel cap, service doors and toolbox
- + Rear and side view safety camera

OPERATOR STATION

- + ROPS protection
- + FOPS guard OPG level 2
- + Pressurized cab
- + Tempered safety glass
- + One-touch lock front window
- + Sun visor & rain deflector
- + A/C, heating and defrosting with automatic control
- + Luch box & cool box, cup holders & ashtray
- + Interior dome light
- + Multi-adjustable low frequency air suspension console and tiltable seat with air springs and double acting hydraulic damper
- + Sliding seat – 90 mm
- + Seat belt with fasten detection

UPPERSTRUCTURE

- + Additional +500 kg counterweight [only on CX210E LC]

OPERATOR STATION

- + Heated seat
- + Front cab guard - vertical bars (OPG level 2)
- + Front cab guard - vertical bars (OPG level 1), available as DIA kit
- + Front mesh screen, available as DIA kit
- + Travel alarm
- + AM/FM Bluetooth radio with antenna and 2 speakers
- + 8 LED work lights (2 cab roof, 1 LH boom, 1 toolbox, 4 all-around)
- + Rain deflector
- + CASE Maximum View Monitor - 270° view with additional left side camera

- + Adjustable armrests
- + Low-effort joystick controls
- + Sliding cockpit - 80 mm
- + Auxiliary select system
- + Aux-in port for personal electronics
- + Multifunction LED color monitor (10"), with silicon switches
- + 22 selectable languages for monitor
- + Anti-theft system (start code system)
- + Split type floor mat
- + 12-volt electric socket
- + 24-volt cigarette lighter
- + One-piece right hand window
- + 4 halogen work lights (2 cab roof, 1 LH boom, 1 toolbox)
- + Windshield wiper / washer
- + Clear (Lexan) roof window with sunshade
- + Storage compartments
- + On-board diagnostic system

ATTACHMENTS

- + Standard boom 5.7 m
- + 2 piece boom
- + Long reach boom 8.7 m
- + Arm 2.94 m
- + Long reach arm 6.4 m
- + Attachment types and names storable in the display

UNDERCARRIAGE

- + 600 mm steel triple grouser shoes
- + Full overlap turntable bearing tub
- + Sealed link chain
- + Lashing points

TELEMATICS

- + SiteConnect module and 3 years advanced SiteWatch subscription with remote monitoring

ATTACHMENTS

- + Arm 2.40 m

UNDERCARRIAGE

- + 500 mm steel triple grouser shoes [only on CX210E NLC]
- + 700 / 800 mm steel triple grouser shoes
- + 900 mm steel triple grouser shoes [for swampy grounds, only on CX210E LC]
- + Triple track guide

SPECIFICATIONS

CX210E

ENGINE

Model _____ FPT NEF6
 Type _____ Water-cooled, 4-cycle diesel, 6-cylinder in line, High pressure common rail system (electric control), Turbocharger with air cooled intercooler, SCRoF, EGR free.
 Number of cylinders / Displacement (l) _____ 6 / 6.7
 Emissions level _____ Stage V
 Bore & stroke (mm) _____ 104 x 132

Rated flywheel horse power

ISO 9249 (kW / hp) _____ 120.4 at 1800 min⁻¹
 ISO 14396 (kW / hp) _____ 124.0 at 1800 min⁻¹

Maximum torque

ISO 9249 (Nm) _____ 644 at 1600 min⁻¹
 ISO 14396 (Nm) _____ 657 at 1600 min⁻¹

HYDRAULIC SYSTEM

Main pumps _____ 2 variable displacement axial piston pumps with regulating system
 Max. oil flow (liter/min) _____ 2 x 211 at 1800 min⁻¹

Working circuit pressure

Boom/Arm/Bucket _____ 34.3 - 37.3 MPa with auto power boost
 Swing circuit (MPa) _____ 29.4
 Travel circuit (MPa) _____ 34.3
 Pilot pump (liter/min) _____ 18
 Working circuit pressure (MPa) _____ 3.9

Boom Cylinders

Bore (mm) _____ 120
 Stroke (mm) _____ 1255

Boom Positioning (2 piece boom only)

Bore (mm) _____ 150
 Stroke (mm) _____ 1090

Arm Cylinder

Bore (mm) _____ 140
 Stroke (mm) _____ 1460

Bucket Cylinder

Bore (mm) _____ 120
 Stroke (mm) _____ 1010

SWING

Swing Motor _____ Fixed displacement axial piston motor
 Maximum swing speed (min⁻¹) _____ 11.5
 Swing torque (Nm) _____ 64,000

FILTERS

Suction filter (µm) _____ 105
 Return filter (µm) _____ 6
 Pilot line filter (µm) _____ 8

ELECTRICAL SYSTEM

Voltage (V) _____ 24
 Alternator (Amp) _____ 90
 Starter (V - kW) _____ 24 - 4.0
 Battery _____ 2x12 V 92 Ah/5 HR

UNDERCARRIAGE

Travel motor _____ Variable displacement axial piston motor
 High travel speed
 (Automatic travel speed shifting) (km/h) _____ 5.6
 Low travel speed (km/h) _____ 3.4
 Drawbar pull (kN) _____ 188
 Number of carrier rollers (each side) _____ 2
 Number of track rollers (each side) _____ 8
 Number of shoes (each side) _____ 49
 Type of shoes _____ Triple grouser shoes
 Grade ability _____ 70% (35°)

NOISE

External guaranteed sound level
 (EU Directive 2000/14/EC) (dB(A)) _____ LwA 101
 Operator cab sound pressure level
 (ISO 6396) (dB(A)) _____ LpA 68

CIRCUIT AND COMPONENT CAPACITIES

	LC	NLC
Fuel tank (l) _____	410	320
Hydraulic system (l) _____	280	265
Hydraulic tank (l) _____	162	145
AdBlue tank (l) _____	84	60

PERFORMANCE DATA MONO LC-NLC		Arm 2.40 m	Arm 2.94 m
Boom length	mm	5700	5700
Bucket radius	mm	1450	1450
Bucket wrist action	°	177	177
A Maximum reach at GRP (LC/NLC)	mm	9240 / 9230	9730
B Maximum reach	mm	9420	9900
C Max. digging depth (LC/NLC)	mm	6110 / 6080	6640 / 6620
D Max. digging height (LC/NLC)	mm	9400 / 9420	9610 / 9640
E Max. dumping height (LC/NLC)	mm	6590 / 6620	6810 / 6840
F Min. swing radius	mm	3620	3660

DIGGING FORCE (ISO 6015)		Arm 2.40 m	Arm 2.94 m
Arm digging force	kN	123	103
with auto power boost	kN	133	112
Bucket digging force	kN	142	142
with auto power boost	kN	154	154

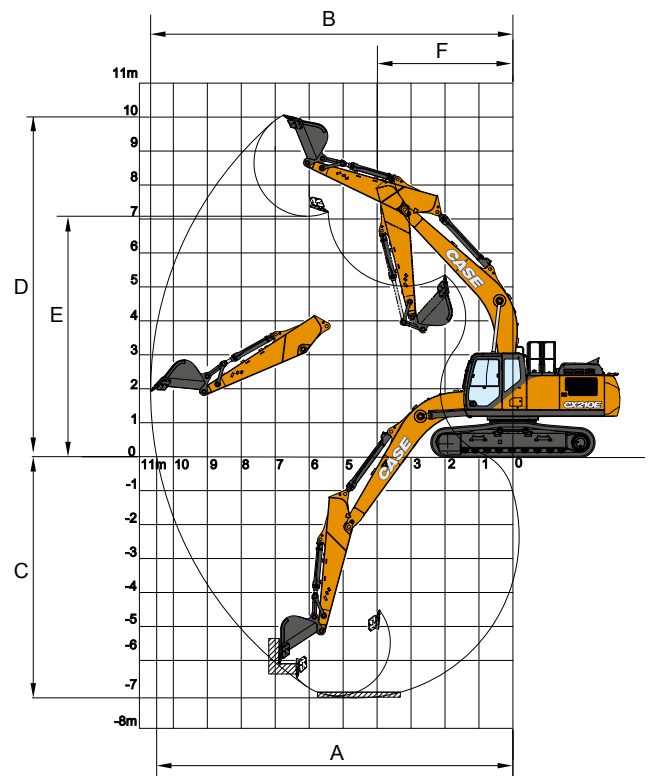

SPECIFICATIONS

CX210E LC-NLC MONO

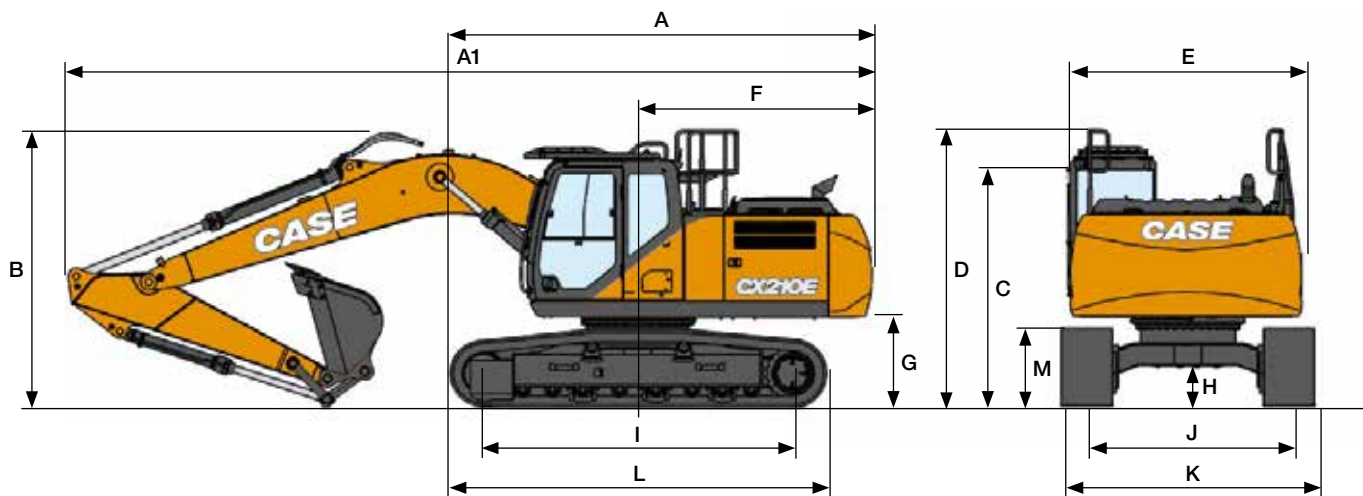

GENERAL DIMENSIONS		Arm 2.40 m	Arm 2.94 m
A	Overall length (without attachment) (LC/NLC)	mm 5050 / 5120	5050 / 5120
A1	Overall length (with attachment) (LC/NLC)	mm 9550 / 9630	9470 / 9540
B	Overall height (to top of boom) (LC/NLC)	mm 3170 / 3190	2980 / 2970
C	Cab height (LC/NLC)	mm 3070 / 3100	3070 / 3100
D	Overall height (to top of guardrail) (LC/NLC)	mm 3150 / 3180	3150 / 3180
E	Upper structure overall width (LC/NLC)	mm 2760 / 2520	2760 / 2520
F	Swing (rear end radius) (LC/NLC)	mm 2830 / 2890	2830 / 2890
G	Clearance height under upper structure (LC/NLC)	mm 1040 / 1070	1040 / 1070
G	Minimum ground clearance (LC/NLC)	mm 440 / 430	440 / 430
I	Wheel base (Center to center of wheels)	mm 3660	3660
J	Track gauge (LC/NLC)	mm 2390 / 1990	2390 / 1990
K	Undercarriage overall width (LC with 600 mm shoes / NLC with 500 mm shoes)	mm 2990 / 2490	2990 / 2490
L	Crawler overall length (LC/NLC)	mm 4470 / 4460	4470 / 4460
M	Crawler tracks height	mm 920	920

WEIGHT AND GROUND PRESSURE LC

With 2.40 m arm, 1.0 m³ bucket, operator, lubricant, coolant, full fuel tank, FOPS protection level 2 and standard counterweight.

LC MONO	Weight	Ground pressure
600 mm grouser shoes	21600 kg	0.045 MPa
700 mm grouser shoes	22040 kg	0.040 MPa
800 mm grouser shoes	22340 kg	0.036 MPa

STD Counterweight = 3800 kg
HEAVY Counterweight = 3800 kg + 500 kg

WEIGHT AND GROUND PRESSURE NLC

With 2.40 m arm, 1.0 m³ CASE bucket, operator, lubricant, coolant, full fuel tank and top guard OPG level 2.

NLC MONO	Weight	Ground pressure
500 mm grouser shoes	22300 kg	0.056 MPa

Counterweight mass 4600 kg

LIFTING CAPACITY

CX210E LC-NLC MONO

		REACH										
		2.0 m		4.0 m		6.0 m		8.0 m		At max reach		
Front	Side											m
LC UNDERCARRIAGE - Short arm 2.40 m, 600 mm shoes, max reach 7.97 m												
8.0 m										5920*	5920*	4.97
6.0 m						5550*	5320			5500*	4340	6.77
4.0 m				8400*	8400*	6250*	5090			5210	3480	7.66
2.0 m				11580*	8410	7360*	4770			4800	3180	7.97
0 m				12570*	8090	7120	4560			4910	3230	7.76
-2.0 m	9990*	9990*		11890*	8130	7090	4530			5720	3740	6.98
-4.0 m				9420*	8420					6710*	5490	5.39
LC UNDERCARRIAGE - Standard arm 2.94 m, 600 mm shoes, max reach 8.45 m												
8.0 m										4170*	4170*	5.72
6.0 m						5030*	5030*			3710*	3710*	7.33
4.0 m				7480*	7480*	5830*	5200	4650*	3320	3660*	3210	8.16
2.0 m				10830*	8670	7050*	4860	4810	3210	3870*	2950	8.45
0 m				12490*	8180	7170	4610	4710	3110	4390*	2980	8.25
-2.0 m	9340*	9340*		12300*	8120	7080	4530			5130	3370	7.53
-4.0 m	17390*	17390*		10440*	8330	6690*	4680			6520*	4590	6.09
LC UNDERCARRIAGE - HEAVY COUNTERWEIGHT - Short arm 2.40 m, 600 mm shoes, max reach 7.97 m												
8.0 m										5920*	5920*	4.97
6.0 m						5550*	5550*			5500*	4600	6.77
4.0 m				8400*	8400*	6250*	5390			5400*	3700	7.66
2.0 m				11580*	8940	7360*	5070			5060	3390	7.97
0 m				12570*	8610	7510	4860			5190	3450	7.76
-2.0 m	9990*	9990*		11890*	8650	7480	4830			6040	3980	6.98
-4.0 m				9420*	8940					6710*	5840	5.39
LC UNDERCARRIAGE - HEAVY COUNTERWEIGHT - Standard arm 2.94 m, 600 mm shoes, max reach 8.45 m												
8.0 m										4170*	4170*	5.72
6.0 m						5030*	5030*			3710*	3710*	7.33
4.0 m				7480*	7480*	5830*	5500	4650*	3530	3660*	3410	8.16
2.0 m				10830*	9190	7050*	5160	5080	3420	3870*	3150	8.45
0 m				12490*	8700	7560	4910	4970	3320	4390*	3190	8.25
-2.0 m	9340*	9340*		12300*	8640	7470	4830			5410	3600	7.53
-4.0 m	17390*	17390*		10440*	8850	6690*	4980			6520*	4890	6.09
NLC UNDERCARRIAGE - Short arm 2.40 m, 500 mm shoes, max reach 7.97 m												
8.0 m										5910*	5910*	5.01
6.0 m						5560*	4940			5500*	4030	6.79
4.0 m				8450*	8450*	6270*	4720			5410*	3250	7.67
2.0 m				11610*	7560	7370*	4410			5240	2970	7.97
0 m				12570*	7260	7770	4210			5380	3020	7.75
-2.0 m	10140*	10140*		11870*	7300	7740	4190			6270	3490	6.96
-4.0 m				9360*	7580					6710*	5100	5.36
NLC UNDERCARRIAGE - Standard arm 2.94 m, 500 mm shoes, max reach 8.45 m												
8.0 m										4170*	4170*	5.75
6.0 m						5030*	5030*			3710*	3630	7.35
4.0 m				7530*	7530*	5850*	4820	4700*	3110	3660*	3000	8.17
2.0 m				10870*	7800	7060*	4500	5250	3000	3870*	2760	8.45
0 m				12500*	7340	7820	4260	5150	2910	4400*	2790	8.24
-2.0 m	9440*	9440*		12290*	7300	7740	4180			5580*	3150	7.51
-4.0 m	17290*	17290*		10400*	7490	6640*	4330			6520*	4280	6.06

* The above loads (kg) are compliant to the ISO standards and refer to the excavator equipped without bucket. The indicated loads are no more than 87% of hydraulic system lift capacity or 75% of static tipping load. Values marked with an asterisk (*) are limited by the hydraulic lifting capacity.

BUCKETS

CX210E LC-NLC MONO

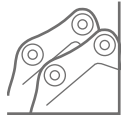

LC DIRECT FIT

Capacity m ³ (ISO7451 HEAPED)	Width mm	Weight kg	Arm 2.40 m	Arm 2.94 m
HEAVY DUTY BUCKETS				
0.45	600	560	○	○
0.60	750	640	○	○
0.76	900	730	○	○
0.85	1000	760	○	○
0.92	1050	800	○	○
0.96	1100	830	○	●
1.08	1200	880	●	●
1.24	1350	970	●	■
1.40	1500	1040	■	—

Capacity m ³ (ISO7451 HEAPED)	Width mm	Weight kg	Arm 2.40 m	Arm 2.94 m
ROCK BUCKETS				
0.44	600	710	○	○
0.59	750	800	○	○
0.75	900	880	○	○
0.85	1000	940	○	○
0.91	1050	980	○	●
0.96	1100	1010	●	●
1.07	1200	1060	●	■
1.23	1350	1150	■	■

Capacity m ³ (ISO7451 HEAPED)	Width mm	Weight* kg	Arm 2.40 m	Arm 2.94 m
90° TILT DITCH CLEANING BUCKETS				
0.68	1800	770	○	○
0.76	2000	810	○	○
0.83	2200	880	○	●
0.91	2400	920	●	●
0.95	2500	950	●	●

Capacity m ³ (ISO7451 HEAPED)	Width mm	Weight* kg	Arm 2.40 m	Arm 2.94 m
DITCH CLEANING BUCKETS				
0.86	1830	650	○	○
0.94	2130	710	○	○

Capacity m ³ (ISO7451 HEAPED)	Width mm	Weight* kg	Arm 2.40 m	Arm 2.94 m
GRADING BUCKETS				
0.97	1800	680	○	○
1.17	2100	740	●	●
1.35	2400	830	●	■

* with bolt-on cutting edge

NLC DIRECT FIT (PRELIMINARY)

Capacity m ³ (ISO7451 HEAPED)	Width mm	Weight kg	Arm 2.40 m	Arm 2.94 m
GENERAL PURPOSE BUCKETS				
0.44	600	540	○	○
0.59	750	610	○	○
0.75	900	660	○	○
0.85	1000	700	○	●
0.96	1100	750	●	●
1.01	1200	790	●	■
1.23	1350	870	■	■
1.39	1500	930	—	—

Capacity m ³ (ISO7451 HEAPED)	Width mm	Weight kg	Arm 2.40 m	Arm 2.94 m
HEAVY DUTY BUCKETS				
0.44	600	590	○	○
0.59	750	640	○	○
0.75	900	720	○	○
0.85	1000	760	○	●
0.96	1100	800	●	●
1.01	1200	850	●	■
1.23	1350	920	■	■
1.39	1500	1000	—	—

Capacity m ³ (ISO7451 HEAPED)	Width mm	Weight kg	Arm 2.40 m	Arm 2.94 m
ROCK BUCKETS				
0.44	600	610	○	○
0.59	750	670	○	○
0.75	900	740	○	○
0.85	1000	780	○	●
0.96	1100	820	●	●
1.01	1200	890	●	■
1.23	1350	940	■	—

Capacity m ³ (ISO7451 HEAPED)	Width mm	Weight kg	Arm 2.40 m	Arm 2.94 m
90° TILT DITCH CLEANING BUCKETS				
0.56	1500	710	○	○
0.68	1800	770	○	○
0.75	2000	810	○	●
0.83	2200	880	●	●
0.91	2400	920	●	■
0.95	2500	950	■	■

Capacity m ³ (ISO7451 HEAPED)	Width mm	Weight kg	Arm 2.40 m	Arm 2.94 m
DITCH CLEANING BUCKETS				
		520	○	○
0.86	1830	650*	○	○
		570	○	●
0.94	2130	710*	●	●

* with bolt-on cutting edge

○ Rated material density up to 2 ton/m³
● Rated material density up to 1.6 ton/m³

■ Rated material density up to 1.2 ton/m³
— Not applicable



LC QUICK COUPLED

NLC QUICK COUPLED (PRELIMINARY)

Capacity m ³ (ISO7451 HEAPED)	Width mm	Weight kg	Arm 2.40 m	Arm 2.94 m
HEAVY DUTY BUCKETS				
0.45	600	560	○	○
0.60	750	640	○	○
0.76	900	730	○	○
0.85	1000	760	○	●
0.92	1050	800	○	●
0.96	1100	830	●	●
1.08	1200	880	●	■
1.24	1350	970	■	—
1.40	1500	1040	—	—

Capacity m ³ (ISO7451 HEAPED)	Width mm	Weight kg	Arm 2.40 m	Arm 2.94 m
GENERAL PURPOSE BUCKETS				
0.44	600	520	○	○
0.59	750	580	○	○
0.75	900	650	○	●
0.85	1000	680	●	●
0.96	1100	730	■	■
1.01	1200	770	■	■
1.23	1350	850	—	—

Capacity m ³ (ISO7451 HEAPED)	Width mm	Weight kg	Arm 2.40 m	Arm 2.94 m
ROCK BUCKETS				
0.44	600	710	○	○
0.59	750	800	○	○
0.75	900	880	○	●
0.85	1000	940	●	●
0.91	1050	980	●	■
0.96	1100	1010	●	■
1.07	1200	1060	■	■
1.23	1350	1150	■	—

Capacity m ³ (ISO7451 HEAPED)	Width mm	Weight kg	Arm 2.40 m	Arm 2.94 m
HEAVY DUTY BUCKETS				
0.44	600	580	○	○
0.59	750	630	○	○
0.75	900	710	○	●
0.85	1000	750	●	■
0.96	1100	790	■	■
1.01	1200	840	■	—
1.23	1350	910	—	—

Capacity m ³ (ISO7451 HEAPED)	Width mm	Weight* kg	Arm 2.40 m	Arm 2.94 m
DITCH CLEANING BUCKETS				
0.86	1830	650	○	●
0.94	2130	710	○	●

Capacity m ³ (ISO7451 HEAPED)	Width mm	Weight kg	Arm 2.40 m	Arm 2.94 m
ROCK BUCKETS				
0.44	600	600	○	○
0.59	750	650	○	○
0.75	900	730	○	●
0.85	1000	770	●	■
0.96	1100	800	■	■
1.01	1200	880	■	—
1.23	1350	930	—	—

Capacity m ³ (ISO7451 HEAPED)	Width mm	Weight* kg	Arm 2.40 m	Arm 2.94 m
GRADING BUCKETS				
0.97	1800	680	○	●
1.17	2100	740	●	■
1.35	2400	830	■	—

Capacity m ³ (ISO7451 HEAPED)	Width mm	Weight kg	Arm 2.40 m	Arm 2.94 m
DITCH CLEANING BUCKETS				
		560	●	●
0.86	1830	690*	●	●
		610	●	■
0.94	2130	750*	●	■

* with bolt-on cutting edge

* with bolt-on cutting edge

HAMMER CX210E

DIRECT FIT

Model	Instal weight kg	Reference machine setting		Arm 2.40 m	Arm 2.94 m
		Flow l/min	Relief pressure MPa		
CB BREAKER					
CB240S	1150	111	19-21	□	□
CB290S	1500	146	21-22	□	□

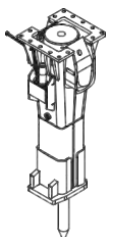

□ Applicable
— Not applicable

□ Applicable with condition
(only light duty works as residential construction or utilities maintenance)

SPECIFICATIONS

CX210E LC-NLC 2 PIECE BOOM

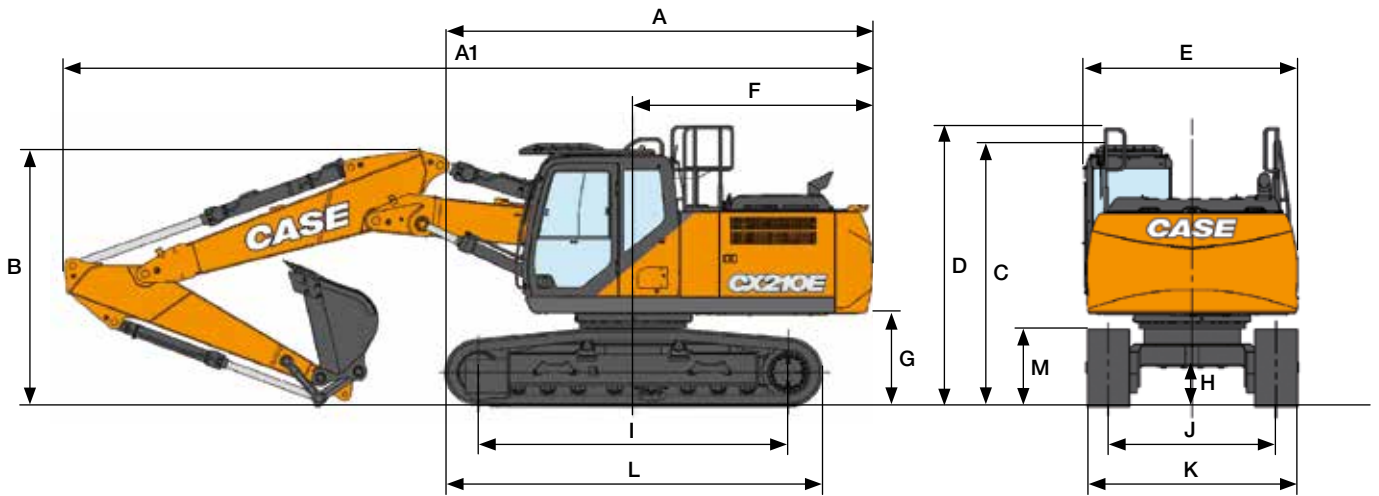

GENERAL DIMENSIONS		Arm 2.40 m	Arm 2.94 m
A	Overall length (without attachment) (LC/NLC)	mm 5050 / 5120	5050 / 5120
A1	Overall length (with attachment) (LC/NLC)	mm 9530 / 9600	9470 / 9540
B	Overall height (to top of boom) (LC/NLC)	mm 3030 / 3040	2890
C	Cab height (LC/NLC)	mm 3070 / 3100	3070 / 3100
D	Overall height (to top of guardrail) (LC/NLC)	mm 3150 / 3180	3150 / 3180
E	Upper structure overall width (LC/NLC)	mm 2760 / 2520	2760 / 2520
F	Swing (rear end radius) (LC/NLC)	mm 2830 / 2890	2830 / 2890
G	Clearance height under upper structure (LC/NLC)	mm 1040 / 1070	1040 / 1070
H	Minimum ground clearance (LC/NLC)	mm 440 / 430	440 / 430
I	Wheel base (Center to center of wheels)	mm 3660	3660
J	Track gauge (LC/NLC)	mm 2390 / 1990	2390 / 1990
K	Undercarriage overall width (LC with 600 mm shoes / NLC with 500 mm shoes)	mm 2990 / 2490	2990 / 2490
L	Crawler overall length	mm 4460	4460
M	Crawler tracks height	mm 920	920

PERFORMANCE DATA		Arm 2.40 m	Arm 2.94 m
1 st boom length	mm	2960	2960
2 nd boom length	mm	2790	2790
Bucket radius	mm	1450	1450
Bucket wrist action	°	177	177
A	Maximum reach at GRP (LC/NLC)	mm 9240 / 9230	9730
B	Maximum reach	mm 9420	9900
C	Max. digging depth (LC/NLC)	mm 5830 / 5800	6350 / 6320
D	Max. digging height (LC/NLC)	mm 10550 / 10580	10910 / 10940
E	Max. dumping height (LC/NLC)	mm 7650 / 7680	8010 / 8040
F	Min. swing radius	mm 2620	2310

WEIGHT AND GROUND PRESSURE

With 2.40 m arm, 1.0 m³ bucket, operator, lubricant, coolant, full fuel tank and FOPS protection level 2.

	Weight	Ground pressure
LC		
600 mm grouser shoes	22500 kg	0.047 MPa
NLC		
500 mm grouser shoes	23200 kg	0.058 MPa

Counterweight LC 3800 kg
Counterweight NLC 4600 kg

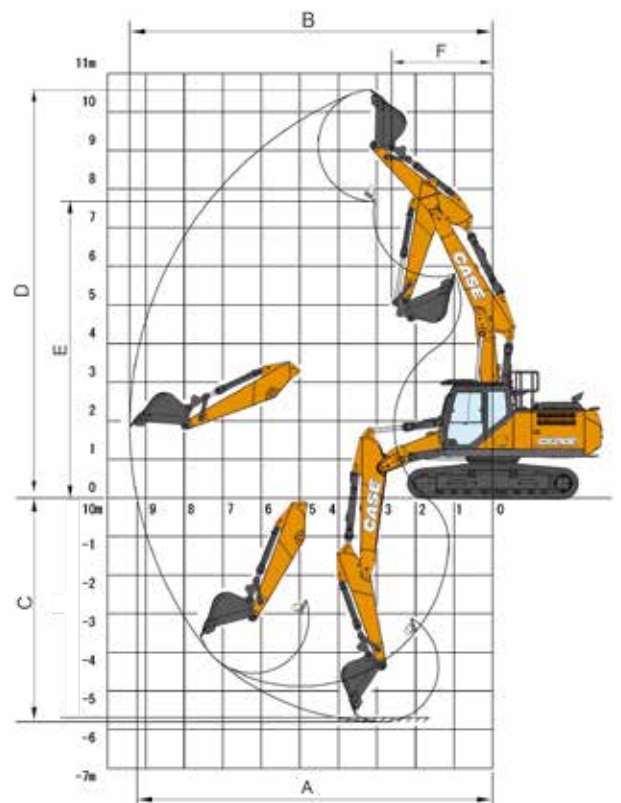

LIFTING CAPACITY (PRELIMINARY)

CX210E LC 2 PIECE BOOM



LC UNDERCARRIAGE - Short arm 2.40 m, 600 mm shoes, max reach 7.97 m

Reach	0.0 m	2.0 m	4.0 m	6.0 m	8.0 m	At max reach	m				
8.0 m			7330*	7330*		6360*	6360*	4.97			
6.0 m			7450*	7450*	5770*	5470	4930*	4330	6.77		
4.0 m			9580*	9570*	6170*	5390	4490*	3430	7.66		
2.0 m		10540*	10540*	12330*	9320	7210*	5170	4480*	3120	7.96	
0 m		15390*	15390*	12410*	8800	7400	4800	4830*	3160	7.75	
-2.0 m	17410*	17410*	24690*	24690*	12660*	8420	7180	4540	5130*	3670	6.98
-4.0 m		18900*	18900*	8680*	8390						

LC UNDERCARRIAGE - Standard arm 2.94 m, 600 mm shoes, max reach 8.45 m

Reach	0.0 m	2.0 m	4.0 m	6.0 m	8.0 m	At max reach	m						
8.0 m						4230*	4230*	5.73					
6.0 m				5390*	5390*	3730*	3730*	7.34					
4.0 m		17100*	17100*	8560*	8560*	5820*	5440*	4280*	3280	3650*	3140	8.17	
2.0 m		18050*	18050*	12000*	9410	6820*	5330	4830	3180	3840*	2870	8.45	
0 m	12910*	12910*	15240*	15240*	12370*	8980	7400	4930	4960	3040	4300*	2900	8.25
-2.0 m	14060*	14060*	20570*	20570*	12560*	8450	7220	4580			5020*	3280	7.53
-4.0 m	14600*	14600*	22650*	22650*	10680*	8310							

* The above loads (kg) are compliant to the ISO standards and refer to the excavator equipped without bucket. The indicated loads are no more than 87% of hydraulic system lift capacity or 75% of static tipping load. Values marked with an asterisk (*) are limited by the hydraulic lifting capacity.

BUCKETS

CX210E LC-NLC 2 PIECE BOOM

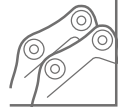

LC DIRECT FIT (PRELIMINARY)

NLC DIRECT FIT (PRELIMINARY)

Capacity m ³ (ISO7451 HEAPED)	Width mm	Weight kg	Arm 2.40 m	Arm 2.94 m
GENERAL PURPOSE BUCKETS				
0.44	600	540	○	○
0.59	750	610	○	○
0.75	900	660	○	○
0.85	1000	700	○	○
0.96	1100	750	○	●
1.01	1200	790	○	●
1.23	1350	870	●	■
1.39	1500	930	■	■

Capacity m ³ (ISO7451 HEAPED)	Width mm	Weight kg	Arm 2.40 m	Arm 2.94 m
GENERAL PURPOSE BUCKETS				
0.44	600	540	○	○
0.59	750	610	○	○
0.75	900	660	○	○
0.85	1000	700	○	●
0.96	1100	750	●	●
1.01	1200	790	●	■
1.23	1350	870	■	—
1.39	1500	930	—	—

Capacity m ³ (ISO7451 HEAPED)	Width mm	Weight kg	Arm 2.40 m	Arm 2.94 m
HEAVY DUTY BUCKETS				
0.44	600	590	○	○
0.59	750	640	○	○
0.75	900	720	○	○
0.85	1000	760	○	○
0.96	1100	800	○	●
1.01	1200	850	●	●
1.23	1350	920	■	■
1.39	1500	1000	■	—

Capacity m ³ (ISO7451 HEAPED)	Width mm	Weight kg	Arm 2.40 m	Arm 2.94 m
HEAVY DUTY BUCKETS				
0.44	600	518	○	○
0.59	750	574	○	○
0.75	900	642	○	○
0.85	1000	680	○	●
0.96	1100	730	●	●
1.01	1200	767	●	■
1.23	1350	846	■	—
1.39	1500	1000	—	—

Capacity m ³ (ISO7451 HEAPED)	Width mm	Weight kg	Arm 2.40 m	Arm 2.94 m
ROCK BUCKETS				
0.44	600	610	○	○
0.59	750	670	○	○
0.75	900	740	○	○
0.85	1000	780	○	○
0.96	1100	820	○	●
1.01	1200	890	●	●
1.23	1350	940	■	■

Capacity m ³ (ISO7451 HEAPED)	Width mm	Weight kg	Arm 2.40 m	Arm 2.94 m
ROCK BUCKETS				
0.44	600	610	○	○
0.59	750	670	○	○
0.75	900	740	○	○
0.85	1000	780	○	●
0.96	1100	820	●	■
1.01	1200	890	●	■
1.23	1350	940	■	—

Capacity m ³ (ISO7451 HEAPED)	Width mm	Weight kg	Arm 2.40 m	Arm 2.94 m
90° TILT DITCH CLEANING BUCKETS				
0.56	1500	710	○	○
0.68	1800	770	○	○
0.75	2000	810	○	○
0.83	2200	880	○	●
0.91	2400	920	●	●
0.95	2500	950	●	●

Capacity m ³ (ISO7451 HEAPED)	Width mm	Weight kg	Arm 2.40 m	Arm 2.94 m
90° TILT DITCH CLEANING BUCKETS				
0.56	1500	710	○	○
0.68	1800	770	○	○
0.75	2000	810	○	●
0.83	2200	880	●	■
0.91	2400	920	■	■
0.95	2500	950	■	■

Capacity m ³ (ISO7451 HEAPED)	Width mm	Weight kg	Arm 2.40 m	Arm 2.94 m
DITCH CLEANING BUCKETS				
0.86	1830	520	○	○
		650*	○	○
0.94	2130	570	○	○
		710*	○	○

Capacity m ³ (ISO7451 HEAPED)	Width mm	Weight kg	Arm 2.40 m	Arm 2.94 m
DITCH CLEANING BUCKETS				
0.86	1830	520	○	○
		650*	○	●
0.94	2130	570	○	●
		710*	●	●

* with bolt-on cutting edge

* with bolt-on cutting edge

○ Rated material density up to 2 ton/m³
● Rated material density up to 1.6 ton/m³

■ Rated material density up to 1.2ton/m³
— Not applicable



LC QUICK COUPLED (PRELIMINARY)

Capacity m ³ (ISO7451 HEAPED)	Width mm	Weight kg	Arm 2.40 m	Arm 2.94 m
GENERAL PURPOSE BUCKETS				
0.44	600	520	○	○
0.59	750	580	○	○
0.75	900	650	○	○
0.85	1000	680	○	●
0.96	1100	730	●	●
1.01	1200	770	●	■
1.23	1350	850	■	■
1.39	1500	910	—	—

Capacity m ³ (ISO7451 HEAPED)	Width mm	Weight kg	Arm 2.40 m	Arm 2.94 m
HEAVY DUTY BUCKETS				
0.44	600	580	○	○
0.59	750	630	○	○
0.75	900	710	○	○
0.85	1000	750	○	●
0.96	1100	790	●	■
1.01	1200	840	●	■
1.23	1350	910	■	—
1.39	1500	990	—	—

Capacity m ³ (ISO7451 HEAPED)	Width mm	Weight kg	Arm 2.40 m	Arm 2.94 m
ROCK BUCKETS				
0.44	600	600	○	○
0.59	750	650	○	○
0.75	900	730	○	○
0.85	1000	770	○	●
0.96	1100	800	●	●
1.01	1200	880	●	■
1.23	1350	930	■	—

Capacity m ³ (ISO7451 HEAPED)	Width mm	Weight kg	Arm 2.40 m	Arm 2.94 m
DITCH CLEANING BUCKETS				
0.86	1830	560	○	○
		690*	○	●
0.94	2130	610	○	●
		750*	●	●

* with bolt-on cutting edge

NLC QUICK COUPLED (PRELIMINARY)

Capacity m ³ (ISO7451 HEAPED)	Width mm	Weight kg	Arm 2.40 m	Arm 2.94 m
GENERAL PURPOSE BUCKETS				
0.44	600	520	○	○
0.59	750	580	○	○
0.75	900	650	○	●
0.85	1000	680	●	●
0.96	1100	730	■	■
1.01	1200	770	■	■
1.23	1350	850	—	—

Capacity m ³ (ISO7451 HEAPED)	Width mm	Weight kg	Arm 2.40 m	Arm 2.94 m
HEAVY DUTY BUCKETS				
0.44	600	580	○	○
0.59	750	630	○	○
0.75	900	710	○	●
0.85	1000	750	●	■
0.96	1100	790	■	■
1.01	1200	840	■	—
1.23	1350	910	—	—

Capacity m ³ (ISO7451 HEAPED)	Width mm	Weight kg	Arm 2.40 m	Arm 2.94 m
ROCK BUCKETS				
0.44	600	600	○	○
0.59	750	650	○	○
0.75	900	730	○	○
0.85	1000	770	●	●
0.96	1100	800	●	■
1.01	1200	880	■	■
1.23	1350	930	■	—

Capacity m ³ (ISO7451 HEAPED)	Width mm	Weight kg	Arm 2.40 m	Arm 2.94 m
DITCH CLEANING BUCKETS				
0.86	1830	560	●	●
		690*	●	■
0.94	2130	610	●	■
		750*	■	■

* with bolt-on cutting edge

○ Rated material density up to 2 ton/m³
● Rated material density up to 1.6 ton/m³

■ Rated material density up to 1.2ton/m³
— Not applicable

SPECIFICATIONS

CX210E LC LONG REACH

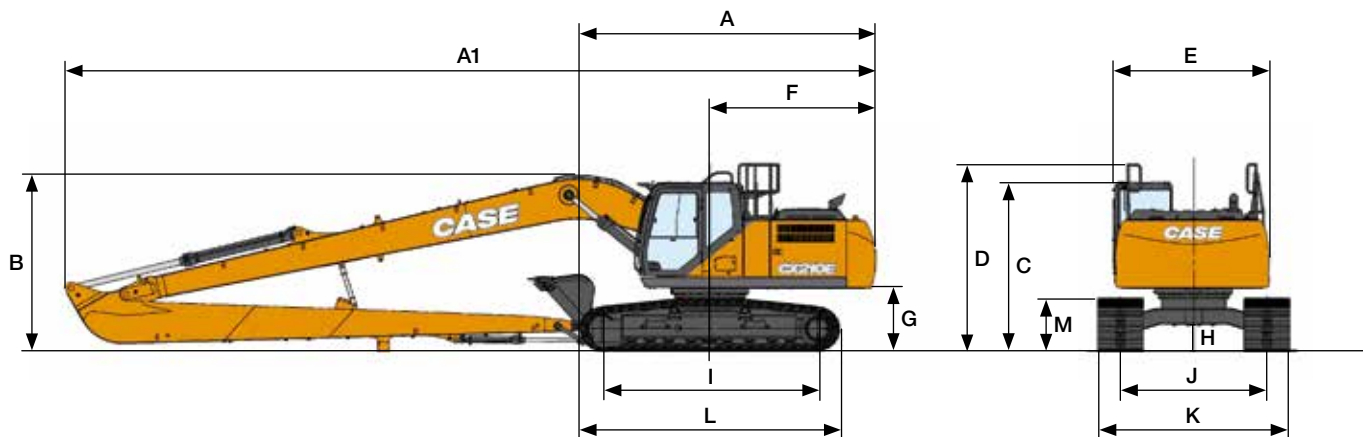

GENERAL DIMENSIONS LONG REACH Arm 6.40 m

Overall length (without attachment)	mm	5000
A Overall length (with attachment)	mm	12520
B Overall height (to top of boom)	mm	3000
C Cab height	mm	2950
D Overall height (to top of guardrail)	mm	3150
E Upper structure overall width	mm	2770
F Swing (rear end radius)	mm	2790
G Clearance height under upper structure	mm	1050
H Minimum ground clearance	mm	440
I Wheel base (Center to center of wheels)	mm	3660
J Track gauge	mm	2390
K Undercarriage overall width (NLC with 800 mm shoes)	mm	3190
L Crawler overall length	mm	4470
M Crawler tracks height	mm	920

DIGGING FORCE (ISO 6015) Arm 6.40 m

Arm digging force	kN	46 kN
Bucket digging force	kN	65 kN

PERFORMANCE DATA LONG REACH Arm 6.40 m

Boom length	mm	8700
Bucket radius	mm	1200
Bucket wrist action	°	178
A Maximum reach at GRP	mm	15490
B Maximum reach	mm	15600
C Max. digging depth	mm	12010
D Max. digging height	mm	12970
E Max. dumping height	mm	10730
F Min. swing radius	mm	5190

WEIGHT AND GROUND PRESSURE

With 6.40 m arm, 0.37 m³ bucket, operator, lubricant, coolant, full fuel tank and FOPS protection level 2.

LONG REACH Weight Ground pressure

800 mm grouser shoes	23780 kg	0.037 MPa
Counterweight 4700 kg		

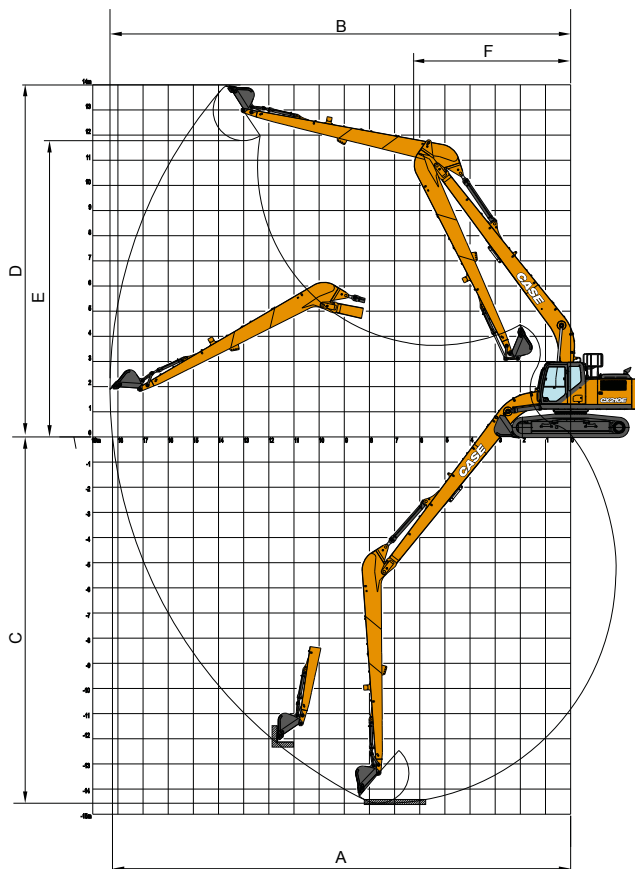

LIFTING CAPACITY (PRELIMINARY)

CX210E LC LONG REACH

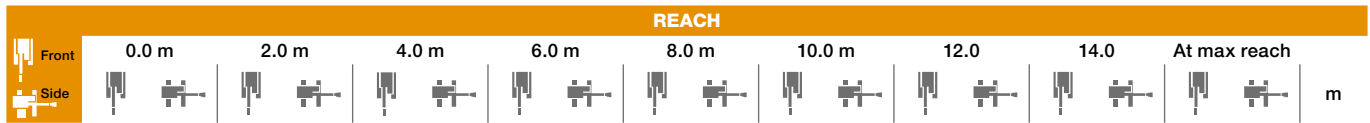

LC UNDERCARRIAGE - Super long arm 6.40 m, 800 mm shoes, max reach 14.40 m

REACH	0.0 m	2.0 m	4.0 m	6.0 m	8.0 m	10.0 m	12.0	14.0	At max reach	m
10.0 m									1360* 1360*	11.83
8.0 m							2130* 2010		1310* 1310*	13
6.0 m						2280* 2280*	2220* 1940		1300* 1300*	13.77
4.0 m					2940* 2940*	2610* 2550	2410* 1830	1740* 1320	1340* 1270	14.23
2.0 m			6950* 6950*	4810* 4810*	3610* 3280	2990* 2330	2640* 1700	2040 1260	1410* 1190	14.4
0 m			3660* 3660*	5890* 4290	4230* 2920	3330 2120	2520 1580	1970 1200	1530* 1150	14.28
-2.0 m		2280* 2280*	3940* 3940*	6530 3920	4330 2680	3160 1960	2430 1490		1730* 1180	13.88
-4.0 m	2950* 2950*	3320* 3320*	4890* 4890*	6380 3780	4190 2550	3070 1870	2380 1440		2030* 1270	13.16
-6.0 m	3840* 3840*	4470* 4470*	6230* 6230*	6400 3810	4180 2540	3060 1870	2410 1470		2390 1460	12.07
-8.0 m		5800* 5800*	8080* 7380	6090* 3960	4290 2640	3170 1960			2980 1860	10.49
-10 m			6810* 6810*	4830* 4280	3460* 2900				3360* 2840	8.14

* The above loads (kg) are compliant to the ISO standards and refer to the excavator equipped without bucket. The indicated loads are no more than 87% of hydraulic system lift capacity or 75% of static tipping load. Values marked with an asterisk (*) are limited by the hydraulic lifting capacity.

BUCKETS

CX210E LONG REACH

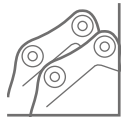

DIRECT FIT (PRELIMINARY)

Capacity m ³ (ISO7451 HEAPED)	Width mm	Weight kg	Arm 6.40 m
GENERAL PURPOSE BUCKETS			
0.21	450	250	○
0.31	600	290	○
0.41	750	330	○
0.52	900	360	●

Capacity m ³ (ISO7451 HEAPED)	Width mm	Weight kg	Arm 6.40 m
DITCH CLEANING BUCKETS			
0.54**	1830	350	●
		480*	■

* with bolt-on cutting edge ** remove for road transport

Capacity m ³ (ISO7451 HEAPED)	Width mm	Weight kg	Arm 6.40 m
90° TILT DITCH CLEANING BUCKET			
0.46	1500	640	■

QUICK COUPLED (PRELIMINARY)

Capacity m ³ (ISO7451 HEAPED)	Width mm	Weight kg	Arm 6.40 m
GP SCOOP BUCKETS			
0.21	450	250	○
0.31	600	280	○
0.41	750	310	●
0.52	900	360	●

Capacity m ³ (ISO7451 HEAPED)	Width mm	Weight kg	Arm 6.40 m
DITCH CLEANING BUCKET			
0.54**	1830	370	■

* with bolt-on cutting edge ** remove for road transport



○ Rated material density up to 2 ton/m³
● Rated material density up to 1.6 ton/m³

■ Rated material density up to 1.2ton/m³
— Not applicable

BUILDING A STRONG CASE.

Since 1842, at CASE Construction Equipment we have lived by an unwavering commitment to build practical, intuitive solutions that deliver both efficiency and productivity.

We continually strive to make it easier for our customers to implement emerging technologies and new compliance mandates.

Today, our global scale combined with our local expertise enables us to keep customers' real-world challenges at the center of our product development.

The vast CASE dealers' network is always ready to support and protect your investment and exceed your expectations, while also providing you with the ultimate ownership experience.

Our goal is to build both stronger machines-and stronger communities. At the end of the day, we do what's right for our customers and our communities so that they can count on CASE.

CNH Industrial
Deutschland GmbH
Case Baumaschinen
Benzstr. 1-3 - D-74076 Heilbronn
DEUTSCHLAND

CNH Industrial
Maquinaria Spain, S.A.
Avenida Aragón 402
28022 Madrid - ESPAÑA

CNH Industrial France, S.A.
16-18 Rue des Rochettes
91150 Morigny-Champigny
FRANCE

CNH Industrial Italia Spa
via Plava, 80
10135 Torino
ITALIA

CASE Construction Equipment
Cranes Farm Rd
Basildon - SS14 3AD
UNITED KINGDOM

NOTE: Standard and optional fittings can vary according to the demands and specific regulations of each country. The illustrations may include optional rather than standard fittings - consult your Case dealer. Furthermore, CNH Industrial reserves the right to modify machine specifications without incurring any obligation relating to such changes.

Conforms to directive 2006/42/EC

CASECE.COM
00800-2273-7373

The call is free from a land line.
Check in advance with your Mobile Operator if you will be charged. Toll free number not available from all calling areas.

