

DOOSAN

Material Handlers

DX230WMH-5 DX250WMH-5

	DX230WMH-5	DX250WMH-5
Maximum power	173.5 hp	173.5 hp
Operating weight	23.7 t	24.9 t
Max. bucket pin height	11.4 m	12 m
Emission standard	Stage IV	Stage IV



BUILT FOR MATERIAL HANDLING

HIGH PRODUCTIVITY AND LOW COST OF OWNERSHIP

Delivers higher productivity and reduced fuel consumption in an efficient and comfortable work environment.

RELIABILITY

Reinforced castings and forged steel pivot points and reinforced heavy-duty arm and boom to withstand high-impact materials. Large, robust boom and arm cylinders for smooth, powerful operation. Advanced pin & bushing technology.

PRODUCTIVITY

Increased lifting capacities and traction force.

SAFETY

Rear and side cameras as standard, large side mirrors, powerful lighting, anti-slip steps. Guard rails on upper structure.

VARIOUS APPLICATIONS

Gooseneck and straight arm configurations are available to suit your different applications.

WORK LIGHTS

As standard: 2 front frame, 4 front & 2 rear cab-mounted, 2 boom mounted and 1 rear side.

FRONT AXLE OSCILLATION

For more comfort. Can be automatically or manually activated for better lifting or digging.

FRAME DURABILITY

Chassis frame and stabilizer frames have been reinforced to reduce stress and improve durability.

TELEMATICS

Monitor your fleet online.

As standard, Doosan Connect system with dual mode (satellite, GSM).

Check productivity, fuel consumption, system warnings, maintenance status, etc.





COMFORT

One of the most spacious cabs in the market, with low noise & vibration levels and excellent all-round visibility. Extra-large door for easy access. Fully adjustable heated air suspension seat, air conditioning with climate control as standard.

OPERATE AT EASE

Exclusive jog shuttle switch, 4 work & 4 power modes, proportional control, user-friendly 7" TFT LCD color monitor. 2 speeds (high, low + creep) with cruise control and 3 front axle oscillation lock modes (On/Off/Auto).

EXCEPTIONALLY POWERFUL

With high torque at low revs, the Stage IV compliant Doosan DLo6 engines are free from Diesel Particulate Filter (DPF) and associated regeneration system for more fuel efficiency.

EFFICIENT FUEL MANAGEMENT

A new SPC (Smart Power Control) system, combined with settable engine shut-off & auto-idle, provides an additional reduction of up to 5%.

ELECTRIC FAN CLUTCH

For optimum cooling, fan speed is controlled electronically by a fan clutch, resulting in lower fan noise and better fuel efficiency.

EASY MAINTENANCE

Easy access to all compartments. Maintenance data directly available from control panel.

ADVANCED FILTRATION

Highest efficiency filters & cleaners remove water, dust & particles to protect your investment optimally.



Stable & comfortable:

Longest wheel base on the market for stability and driving performance that make the whole difference.

Efficient & safe:

Excellent ground clearance for better protection in rough terrain.



Wastegate turbocharger: Diverts exhaust gases away from the turbine wheel to better regulate max boost pressure & protect engine. Also reduces lag time before turbo begins to spool/ create boost maximising torque, plus reduces wear in high rpm & low load conditions. Turbocharger increases the density of the air, enabling the engine to produce more power with few effects from altitude.

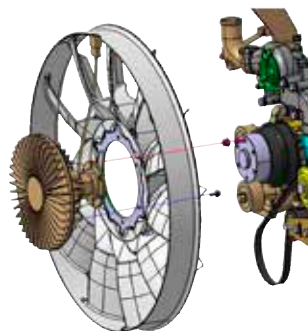

Electrical viscous fan clutch: For optimum cooling, fan speed is controlled electronically by a fan clutch, resulting in a quieter fan and better fuel efficiency.



TOP PERFORMANCE AND FUEL EFFICIENCY

THE POWER TO RAISE PRODUCTIVITY

The DX230WMH-5 and DX250WMH-5 take even the heaviest tasks in their stride with efficient, dependable performance that saves you time and money:

- Improved hydraulic system uses the engine's power more effectively, maximising pump output and offering more comfort, smoothness and accuracy
- Increased lifting capacities and traction force combine for performance you can rely on, day after day
- Greater fuel efficiency means you can keep costs down and reduce environmental impact

OPTIMIZED POWER MANAGEMENT

The DX230WMH-5 and DX250WMH-5 are equipped with a Doosan engine. Famous for excellent fuel efficiency, reliability and long service life, they combine exceptional power output and high torque at low revs. Engine is fitted with common rail fuel injection combined with a wastegate turbocharger, which increases the density of the air, enabling the engine to produce more power. Selective Catalytic Reduction (SCR) technology - combined with a Diesel Oxidation Catalyst (DOC) - ensures compliance with Stage IV regulations. As there is no need for a particulate filter, there is no need for regeneration.

If the engine is the heart, the e-EPOS is the brain - providing a perfectly synchronized communication link between the engine's ECU (Electronic Control Unit) and the hydraulic system. A CAN (Controller Area Network) system enables a constant flow of information between engine and hydraulic system, so that power is delivered exactly as needed.

EFFICIENT FUEL MANAGEMENT

- Choice between 4 power modes and 4 working modes guarantees optimum performance in all conditions
- SPC (Smart Power Control): reduces engine RPM during low load demand & ensures pump torque control, thus ensuring fuel efficiency and low emissions
- Engine auto-shut-off: shuts down the engine after the machine has been idling for a specified time
- Electronic control of fuel consumption optimizes efficiency
- Auto-idle function saves fuel
- Eco guidance in real-time: eco gauge provides information about fuel consumption relative to machine performance in real-time. By trying to keep the right-hand LED bar from rising, the operator can teach himself how to save fuel and work efficiently
- For optimum cooling, fan speed is controlled by an electrical viscous fan clutch, resulting in a quieter fan & better fuel efficiency





RELIABILITY – THE HABIT OF A LIFETIME

In your profession, you need equipment you can depend on. At Doosan, we use highly specialized design and analysis tools to make sure our machines are as robust and durable as can be. Our materials and structures undergo stringent testing for strength and resilience under the most extreme conditions.

And we continually manufacture the most durable machines to ensure lower cost of ownership.

DESIGNED FOR LONG-TERM, ALL-ROUND, HEAVY-DUTY PERFORMANCE

UNDERCARRIAGE DURABILITY

A rigid, welded frame provides excellent durability. Efficient routing of hydraulic lines, transmission and rear differential protection and heavy-duty axles make the undercarriage perfect for material handling applications. An oscillating axle lock is available.

DRIVE LINE CONCEPT

The travel motor and powershift transmission control in the drive line provide comfortable travel due to increased smoothness, improved hydraulic retarding and improved gear shifting.

ADVANCED DISC BRAKE SYSTEM

The improved system allows a more efficient braking of the machine. This eliminates the rocking effect associated with working on wheels. The ZF axles are designed for low maintenance, and the oil change intervals have been increased to 2000 hours, further reducing owning and operating costs.

HEAVY-DUTY AXLES

The front axle offers wide oscillating and steering angles. The transmission is mounted directly on the rear axle for protection and optimum ground clearance.

ADVANCED FILTRATION

- Fuel filters & water separator: a filter-type high-performance water separator effectively captures moisture in the fuel, reducing impurities and helping minimize any fuel-related issues. Pre-filters and dual main filters as standard minimize fuel system failures
- Air cleaner: The large capacity forced air cleaner removes over 99% of airborne particles, reducing the risk of engine contamination and extending the cleaning and cartridge change intervals

PIN & BUSHING ADVANCED TECHNOLOGY

Highly lubricated metal is used for the boom pivot to increase the component's lifetime and lengthen greasing intervals. The attachment pivot features EM (Enhanced Macrosurface) bushings, which have a tailored surface pattern and self-lubricating coating to optimize greasing and make removal of debris more efficient. Ultra-hard wear-resistant discs & attachment pivot polymer shim increase durability even more.

STRENGTHENED BOOM & ARM

Finite Element Analysis has been used to calculate the best load distribution throughout the boom structure. Combined with thicker material, this means that element fatigue is limited and both reliability and component life are increased. To better protect the base of the arm, reinforced bars have been added and the arm center and end boss have been strengthened.



Exclusive independent stabilizer design:

1. Large reinforced covers protect the stabilizer cylinders
2. The stabilizers are kept well within the machine envelope and the position of the pins is kept high to avoid bumping while moving over the ground
3. Parts in contact with the ground have been carefully designed to prevent damage to the surface
4. Wide pads to reduce ground pressure



1. Large sun roof
2. Sun visor
3. Storage compartment for sunglasses
4. Window grip
5. Hot/cool box
6. Upper front window includes a sun shade and is strut-assisted for easy, reliable adjustment
7. Photo sensor detects radiant energy from the sun and adjusts temperature automatically
8. Joysticks and switches are integrated in adjustable control consoles
9. Improved visibility on the bottom right
10. Separate seat height adjustment lever and cushion tilting function
11. Pedal for auxiliary control 1 & 2 ways
12. Flat, spacious, easy-to-clean floor
13. Engine emergency stop switch

OPERATING IN HIGH COMFORT

THE IDEAL WORKSPACE – DESIGNED AROUND YOU

The DX230WMH-5 and DX250WMH-5 are designed to provide you with the best possible working conditions. The pressurized cab is ISO-certified for your safety. Its spacious interior offers a fully adjustable, heated air suspension seat. Comfortably seated, you have easy access to several storage compartments and a clear all-round view of the worksite. Noise and vibration levels have been reduced, while air conditioning and automatic climate control allow you to keep working for hours on end without feeling tired.

BEST-IN-CLASS OPERATOR ENVIRONMENT

Doosan Wheeled Excavators are powered by industry-leading engines that save on fuel and meet the latest Stage IV European regulations in addition to all noise regulations. The low levels of cab vibration and noise provide exceptional operator comfort - and the cab air is filtered to ensure a healthy work environment.

COMFORTABLE & SAFE WORKSPACE

Doosan offers one of the most spacious cabs in the market. The elevating cab provides excellent visibility and high flexibility.

FULLY ADJUSTABLE STEERING COLUMN

The easily adjustable and narrow steering column ensures optimal visibility.

HEATED AIR SUSPENSION SEAT (STANDARD)

In addition to being adjustable and providing lumbar support, the seat has an air suspension system to reduce vibrations. It also features a seat heating system (activated at the touch of a button). A storage box has been placed under the seat for extra convenience.

AIR CONDITIONING WITH CLIMATE CONTROL

The operator can choose from 5 different modes to regulate the airflow, while the system adjusts the air temperature & fan speed to maintain the operator's selected temperature. A recirculated air function is also available.

MP3/USB RADIO

MP3 player (MP3/USB radio with CD player optional).

STORAGE SPACE

The new cab contains 7 storage compartments including one hot/cool box (linked to the HVAC system).

CABSUS MOUNT

The cab's new suspension system (CabSus mount) dampens high vibrations and provides outstanding protection against impact. The system absorbs shocks and vibrations much more effectively than a conventional viscous suspension system.

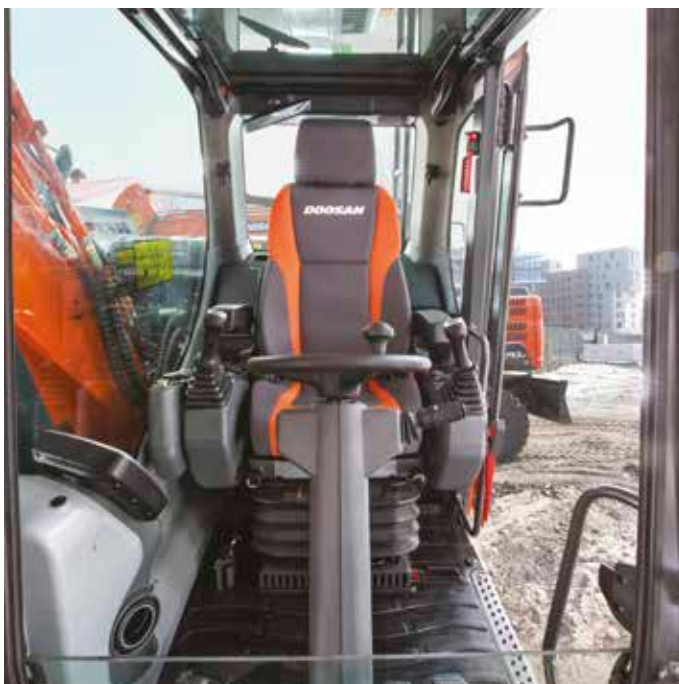



Simple control: Doosan's exclusive jog shuttle switch for easy and precise control over all machine functions.



1. Power Boost switch & One-touch deceleration switch
2. Thumb wheel switch allows proportional control of attachments
3. FNR selector switch
4. "Short stroke" joysticks enable easy, precise control of all operations
5. Axle RAM lock
6. Exclusive jog shuttle switch
7. Working lights switch
8. Smart Power Control
9. Travel speed selector switch
10. Climate control
11. Remote control of radio
12. Parking brake
13. Floating boom switch
14. Power socket 12V

WITH YOUR SAFETY IN MIND

Standard cab and boom lights, large side mirrors, rear and side view cameras improve all-round visibility and thus safety. Other standard safety features: anti-slip plates, automatic overheating alarm warning, low oil pressure sensor, engine emergency cut-off switch, auxiliary mode switch (allows a safe level of hydraulics operation in case of EPOS failure), overload warning device. Optional travel/swing alarm is also available.



TOTAL CONTROL IN ALL SIMPLICITY

THE HIGHEST STANDARDS OF EFFICIENCY AT YOUR FINGERTIPS

The advanced & user-friendly technologies are just some of the many advantages of this new generation. The ergonomic controls and the easy-to-view color monitor place the machine firmly in your hands.

- The new multi-function 7" TFT LCD monitor displays a comprehensive range of useful technical information, allowing you to check the machine's status and settings at a glance
- Highly sensitive & low-effort joysticks and clear convenient controls enable you to work safely, smoothly & confidently with minimum effort for increased comfort, efficiency and production
- Doosan's unique jog shuttle switch gives you easy, precise control over all machine functions
- Proportional auxiliary flow means precision control, smoothness & efficiency when using attachments

TFT LCD COLOR MONITOR PANEL

The upgraded 7" Thin-Film-Transistor (TFT is a technology that improves image quality) LCD panel features a day and night display. The user-friendly monitor gives full access to machine settings and maintenance data. Any abnormality is clearly displayed on the screen, allowing you to work safely and confidently with an accurate overview of all conditions. All functions are totally controllable, directly via the screen or using the exclusive jog shuttle switch.

1. Fuel consumption level: current, total & daily average fuel consumption
2. Fuel level
3. AdBlue® level
4. Eco symbol: changes color when operating conditions change (idle, normal or loading)
5. Eco gauge: shows the average fuel efficiency
6. Engine coolant and hydraulic oil temperatures
7. Warning symbols
8. New shortcut menu: displayed on the right for rapid access to main functions
9. Optional anti-theft password-controlled starting
10. Oil filter information
11. Attachment management: stores up to 10 different attachment presets, enabling the operator to set hydraulic flow & pressure according to his needs

DYNAMIC POWER MANAGEMENT

- Activating the power boost control system increases hydraulic lifting capacity by 10%
- A one-touch deceleration button immediately reduces engine speed to low or idle
- Auto-idling starts 4 seconds after all controls are returned to neutral - decreasing fuel consumption and reducing noise levels in the cab

INTELLIGENT FLOATING BOOM MODE

- The 'intelligent floating boom' function allows the boom to move up & down freely according to the application. When loading materials, the operator cannot see the end of the attachment – so the boom moves down freely under its own weight to minimize shock when the attachment touches the ground, reducing stress on the machine and the attachment

4 WORK MODES & 4 POWER MODES

- Deliver the needed power according to your specific application while minimizing fuel consumption





SIMPLE MAINTENANCE WITH MAXIMUM UPTIME

EXCELLENT SERVICE ACCESSIBILITY

Short maintenance operations at long intervals mean you can depend on your equipment being available on-site when it's needed. Our machines are designed for simple routine maintenance, while skilled Doosan technicians are available to provide extra support, should you need it. Choose the package you need from a broad range of service agreements to get the most out of your machine. Uptime, productivity and residual value are all maximized, making these material handlers an economical and rewarding choice.

MAINTENANCE ACCESS MADE SIMPLE

- Large guard rails are installed along with anti-slip steps and plates, for safer, easier access to the whole upper structure
- The cab's air-conditioning filter is lockable and placed on the side of the cab for easy access
- A battery cut-off switch makes it easy to disconnect the battery during long-term storage
- The hour meter display can be easily checked from ground level
- Shut-off valves have been fitted on the pre-filter piping line and fuel tank drain piping to make servicing easier and prevent pollution from leakage
- Engine parts can be easily reached via the top and side panels
- For extra accessibility and servicing convenience, all filters (engine oil filter, fuel pre-filter, fuel filter and pilot filter) are located in the pump compartment

LONGER SERVICE INTERVALS

More than 99.5% of foreign particles are filtered out in oil return filters and engine oil filters - so the oil & filter change interval is longer.

SCR TANK

Connected to the ECU, sensors in tank detect low level of AdBlue® & any system malfunction

CENTRALIZED GREASING POINTS

To make maintenance easier, the greasing points have been centralized.

NO DPF

Building further on the success of the DLo6 engine, the new Stage IV Doosan DLo6 engine has no need for a DPF filter to meet the Stage IV emissions requirements - which means no maintenance required, so more uptime!



TECHNICAL SPECIFICATIONS

ENGINE

Designed to deliver superior performance and fuel efficiency, the Doosan Stage IV diesel engine fully meets the latest emissions regulations. To optimize machine performance, the engine uses high-pressure fuel injectors, air-to-air inter-cooler and electronic engine controls. 4-Cycle Water-Cooled, Wastegate Turbocharger, Exhaust Gas Recirculation (EGR) & Selective Catalytic Reduction (SCR) with no Diesel Particulate Filter (DPF).

Model

Doosan DLo6

No. of cylinders

6

Rated power at 1800 rpm

SAE J1995 129.4 kW (173.5 hp)

SAE J1349 123.2 kW (165.2 hp)

Max. torque

82 kgf·m (804 Nm) @ 1400 rpm

Idle (low - high)

800 [±10] - 2000 [±25] rpm

Displacement

5890 cm³

Bore × stroke

100 mm × 125 mm

Starter

24 V / 6 kW

Batteries - Alternator

2 × 12 V, 150 Ah - 24 V, 80 A

Air filter

Double element air cleaner and pre-filtered Turbo dust separator

UNDERCARRIAGE

Extremely robust construction throughout - made of high-quality, durable materials, with all welded structures designed to limit stresses. Heat-treated connecting pins. 10.00-20-16PR (OTR) double tires with tire spacer. Heavy-duty front axle with automatic or operator-controlled (on/off/auto) front axle oscillation lock.

Front axle oscillation

+/- 8° with automatic ram lock

BRAKES

Dual multi-disc circuit with sintered metal discs for extended service life. Braking system activated by a pump and accumulator circuits. Spring-applied, hydraulically released parking brake mounted on the transmission shaft.

HYDRAULIC SYSTEM

The e-EPOS (Electronic Power Optimising System) is the brain of the excavator - minimising fuel consumption and optimising the efficiency of the hydraulic system for all working conditions. To harmonize the operation of the engine and the hydraulics, the e-EPOS is connected to the engine's electronic control unit (ECU) via a data transfer link.

- The hydraulic system enables independent or combined operations
- 2 travel speeds offer either increased torque or high speed
- Cross-sensing pump system for fuel savings
- Auto-deceleration system
- 4 operating modes, 4 power modes
- Flow and pressure control of auxiliary hydraulic circuits from control panel
- Computer-aided pump flow control

Main pumps

2 × parallel, bent axis, axial piston pumps

Maximum flow at 2000 rpm 2 × 236 l/min

Pilot pump

Gear pump

Maximum flow at 2000 rpm 27.4 l/min

Steering pump

Gear pump

Maximum flow at 2000 rpm 69 l/min

Brake pump

Gear pump

Maximum flow at 2000 rpm 22.4 l/min

Relief valve settings

Implement 380 bar (387.5 kgf/cm²)

Travel/Work 343 bar (350 kgf/cm²)

Pilot 40 bar (40.8 kgf/cm²)

Steering 180 bar (183.5 kgf/cm²)

Brake 154 bar (157 kgf/cm²)

HYDRAULIC CYLINDERS

High-strength steel piston rods and cylinder bodies. Shock-absorbing mechanism fitted in all cylinders for shock-free operation and extended piston life.

Cylinders	Quantity	Bore × rod diameter × stroke (mm)
One-piece boom	2	120 × 85 × 1240
Arm	2	115 × 80 × 1068
Attachment	1	120 × 80 × 1060
Stabilizers	2/4	130 × 80 × 391

CAB

ROPS cab, large and roomy interior. One-way travel pedal with FNR switch on the right joystick. Audio system with remote control, independently adjustable joystick consoles. Excellent all-round visibility, transparent roof hatch, 2-piece sliding door window, narrow and easily adjustable steering column. The removable lower front glass can be stored behind the seat. Interior lighting. The pressurized and filtered cab air is supplied by numerous vents. Climate-control provides fast defrosting and high cooling and heating performance. Viscous/spring mounted suspension cushions reduce vibrations. Heated air suspension seat with adjustable seat suspension, height, tilt, recline and forward-backward settings. Adjustable, easy to read 7" LCD color monitor provides real-time information on machine functions and diagnostic information and is switchable to rear view camera or side view camera.

A-weighted emission sound pressure level at the operator's position, LpAd (ISO 6396:2008)

63 dB(A)

A-weighted sound power level, LwAd (2000/14/EC)

Declared: 103 dB(A)

Measured: 101.5 dB(A)

SWING MECHANISM

The swing mechanism uses an axial piston motor, driving a 2-stage planetary reduction gear bathed in oil for maximum torque.

- Swing bearing: single-row, shear type ball bearing with induction hardened internal gear
- Internal gear and pinion immersed in lubricant
- Increased swing torque reduces swing time
- The swing brake for parking is activated by spring and released hydraulically

Maximum swing speed

9.8 rpm

Maximum swing torque

6387 kgf·m

COMPONENT WEIGHTS

Item	Unit	DX230WMH-5	DX250WMH-5	Remarks
Upper structure without front	kg	10850	12065	With counterweight
Undercarriage	kg	7600	7600	
Front assembly	kg	3300	4010	
Counterweight	kg	4000	5200	
Boom	kg	1800	2000	Including bushing
Arm - Gooseneck	kg	1100	1200	Including bushing
Arm - Straight	kg	1380	1380	Including bushing
Hydraulic elevating cab	kg	1190	1190	
Stabilizer	kg	1221	1221	
Stabilizer cylinder (each)	kg	113	113	

FLUID CAPACITIES

Fuel tank	300 l
Cooling system (radiator)	24 l
Hydraulic oil system	205 l
Engine oil	25 l
Swing drive	5 l
Front axle hub	2 × 2.5 l
Rear axle hub	2 × 2.5 l
Front Axle Case	11 l
Rear Axle Case	14.5 l
Transmission	2.5 l
Urea tank	31.5 l

DRIVE

The wheels are driven by an axial piston motor via a two-speed powershift transmission. In addition to the two-speed powershift transmission, there is also an economy mode and a switch for the creep speed. A button makes it possible to pass from high to low in work mode.

Two travel speed ranges offer a choice between increased torque or high speed.

Travel speed (creep - low - high)

4 - 9 - 20 km/h

Maximum traction

12 t

Minimum turning radius

7.2 m

Maximum gradeability

33° / 65%

DIMENSIONS

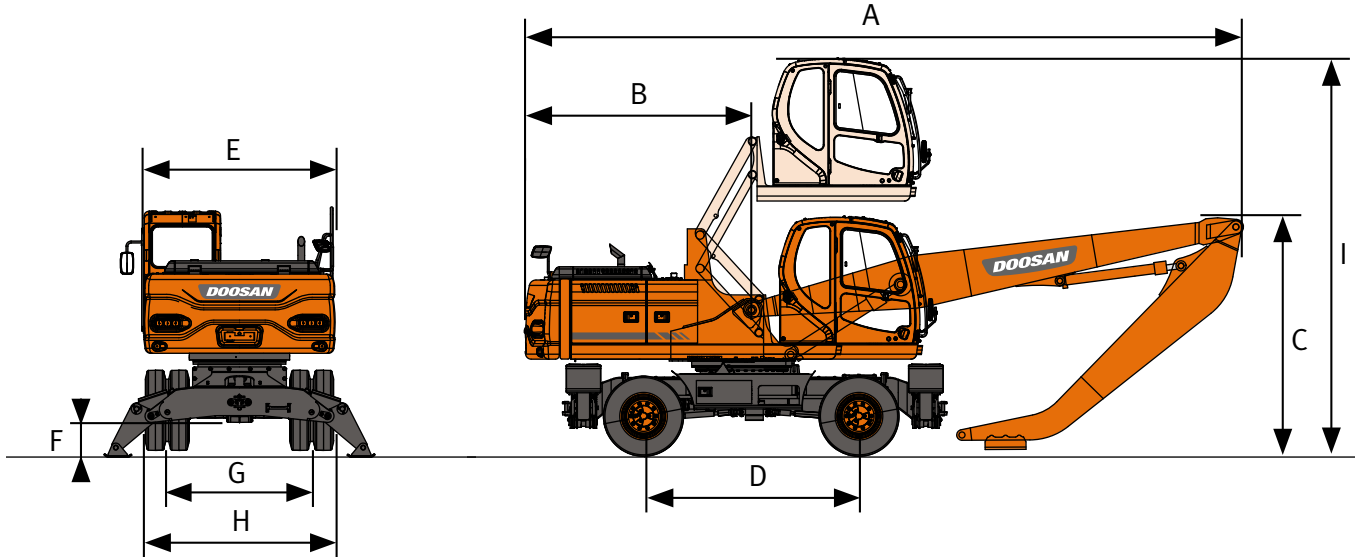

DIMENSIONS

	Unit	DX230WMH-5		DX250WMH-5	
		6100		6500	
Boom length	mm				
Arm length	mm	4200 Gooseneck	4000 Straight	4500 Gooseneck	4000 Straight
A Shipping length	mm	9145	9000	9685	9750
B Tail swing radius	mm	2755	2755	2860	2860
C Shipping height (boom)	mm	2925	3280	3310	3360
D Wheel base	mm	2850	2850	2850	2850
E Upper housing width	mm	2700	2700	2700	2700
F Ground clearance	mm	350	350	350	350
G Tread width	mm	2114	2114	2114	2114
H Shipping width	mm	2750	2750	2750	2750
I Height over cab	mm	5640	5640	5640	5640

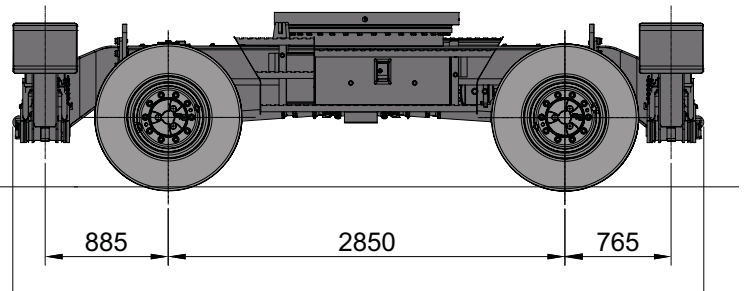
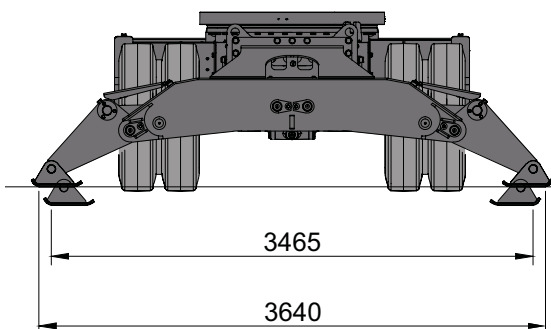

WORKING RANGE

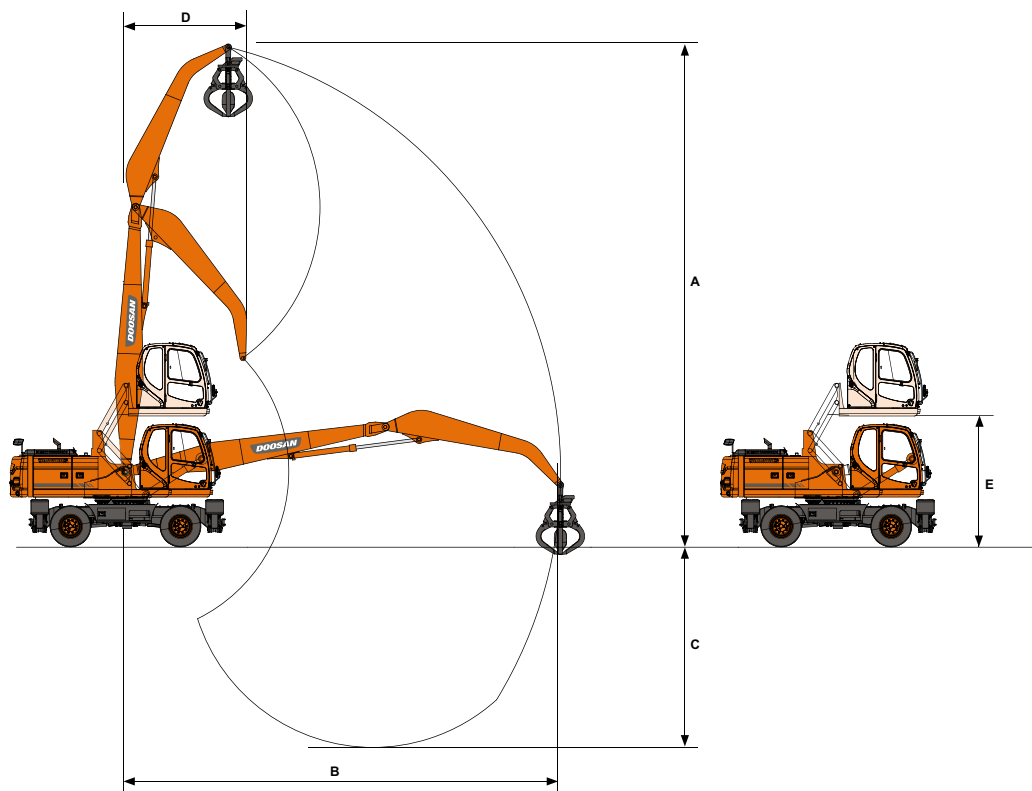















WORKING RANGE

	Unit	DX230WMH-5		DX250WMH-5	
Boom length	mm	6100		6500	
Arm length	mm	4200 Gooseneck	4000 Straight	4500 Gooseneck	4000 Straight
A Max. bucket pin height	mm	11380	11675	12000	12000
B Max. working reach	mm	10045	10090	10700	10400
C Max. working depth	mm	4245	3970	4700	4200
D Min. swing radius	mm	2300	2300	2600	2600
E Elevating height	mm	3755	3755	3755	3755

LIFTING CAPACITIES DX230WMH-5

W/O BUCKET • CHASSIS FRAME ATTACHMENT: F-STABILIZER + R-STABILIZER DOWN

(UNIT: KG)

A	3.0 m		4.5 m		6.0 m		7.5 m		9.0 m		10.5 m		Max. reach		
B															A



Boom 6.1 m • Gooseneck arm 4.2 m • Counterweight 4.0 t

12.0 m															
10.5 m			7295*	7295*									5913*	5913*	5.11
9.0 m					5843*	5843*							4999*	4999*	7.08
7.5 m					5725*	5725*	5157*	5157*					4641*	4641*	8.34
6.0 m			6935*	6935*	5924*	5924*	5201*	5201*	4628*	4083			4512*	3948	9.18
4.5 m	10594*	10594	7862*	7862*	6357*	6357*	5383*	5383*	4652*	4036			4322*	3562	9.71
3.0 m			9053*	9053*	6876*	6876*	5595*	5228	4698*	3952			4119*	3360	9.99
1.5 m			9875*	9875*	7240*	7047	5716*	5055	4637*	3863			3915*	3292	10.04
0.0 m	5815*	5815*	9781*	9781*	7207*	6801	5597*	4918	4390*	3795			3671*	3349	9.85
-1.5 m	6874*	6874*	8762*	8762*	6631*	6631*	5101*	4843	3780*	3772			3335*	3335*	9.42

Boom 6.1 m • Straight arm 4.0 m • Counterweight 4.0 t

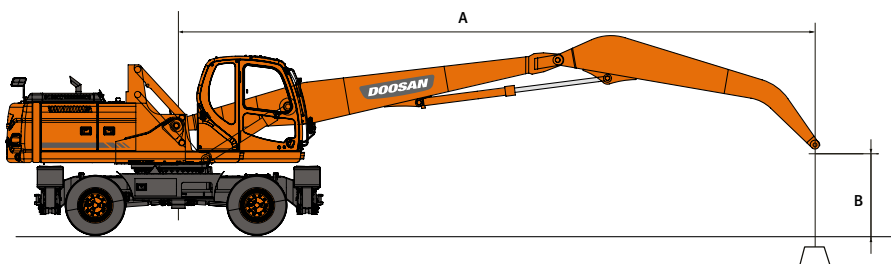
12.0 m															
10.5 m			7386*	7386*									6113*	6113*	5.19
9.0 m			6628*	6628*	5790*	5790*							4877*	4877*	7.14
7.5 m			6542*	6542*	5656*	5656*	5035*	5035*					4367*	4324	6.39
6.0 m			6991*	6991*	5858*	5858*	5068*	5068*	4441*	3842			4130*	3664	9.22
4.5 m	11045*	11045*	7931*	7931*	6282*	6282*	5237*	5186	4452*	3818			4036*	3306	9.75
3.0 m			9068*	9068*	6773*	6773*	5429*	5027	4464*	3748			3761*	3126	10.03
1.5 m			9750*	9750*	7074*	6861*	5506*	4865	4378*	3673			3473*	3077	10.08
0.0 m			9466*	9466*	6948*	6636*	5326*	4743	4066*	3618			3126*	3126*	9.89
-1.5 m	5707*	5707*	8269*	8269*	6262*	6262*	4747*	4688	3325*	3325*			2658*	2658*	9.47



 : Rating over front.
 : Rating over side or 360°.

- Lifting capacities are in compliance with ISO 10567:2007(E).
- The load point is at the end of the arm.
- * = The nominal loads are based on hydraulic capacity.
- The nominal loads shown do not exceed 75% of tipping loads or 87% of hydraulic lifting capacity.
- For lifting capacity with bucket, simply subtract the actual weight of the bucket from the values.
- The configurations indicated do not necessarily reflect the standard equipment of the machine.

LIFTING CAPACITIES

DX250WMH-5

W/O BUCKET • CHASSIS FRAME ATTACHMENT: F-STABILIZER + R-STABILIZER DOWN

(UNIT: KG)

A	3.0 m		4.5 m		6.0 m		7.5 m		9.0 m		10.5 m		Max. reach		
B															A

Boom 6.5 m • Gooseneck arm 4.5 m • Counterweight 5.2 t

12.0 m					6128*	6128*							9625*	9625*	3.47
10.5 m					6128*	6128*							5978*	5978*	6.40
9.0 m					5742*	5742*	5212*	5212*					5064*	5064*	8.06
7.5 m					5731*	5731*	5123*	5123*	4651*	4651*			4601*	4601*	9.18
6.0 m			7097*	7097*	6004*	6004*	5232*	5232*	4640*	4640*			4302*	4019	9.95
4.5 m	11131*	11131*	8120*	8120*	6498*	6498*	5461*	5461*	4711*	4673			4078*	3676	10.44
3.0 m			9381*	9381*	7067*	7067*	5717*	5717*	4789*	4562	4002*	3597	3882*	3492	10.70
1.5 m			10230*	10230*	7462*	7462*	5872*	5812	4790*	4448	3861*	3546	3683*	3429	10.74
0.0 m	14608*	14608*	10125*	10125*	7456*	7456*	5799*	5648	4620*	4358	3515*	3511	3449*	3449*	10.57
-1.5 m	12109*	12109*	9128*	9128*	6930*	6930*	5381*	5381*	4164*	4164*			3138*	3138*	10.17

Boom 6.5 m • Straight arm 4.0 m • Counterweight 5.2 t

12.0 m													14764*	14764*	2.28
11.0 m			7821*	7821*									7423*	7423*	5.03
10.0 m			7192*	7192*	6223*	6223*							6019*	6019*	6.55
9.0 m			6927*	6927*	5963*	5963*	5370*	5370*					5333*	5333*	7.64
8.0 m			6910*	6910*	5911*	5911*	5232*	5232*					4904*	4697	8.47
7.0 m			7124*	7124*	6005*	6005*	5232*	5232*	4641*	4254			4598*	4150	9.12
6.0 m			7569*	7569*	6220*	6220*	5313*	5313*	4628*	4265			4360*	3786	9.61
5.0 m	11445*	11445*	8230*	8230*	6524*	6524*	5443*	5443*	4653*	4236			4159*	3538	9.98
4.0 m			9018*	9018*	6873*	6873*	5591*	5591*	4688*	4187			3978*	3373	10.24
3.0 m			9764*	9764*	7199*	7199*	5724*	5477	4706*	4128			3802*	3272	10.39
2.0 m			10220*	10220*	7417*	7417*	5796*	5357	4678*	4067			3622*	3227	10.44
1.0 m			10222*	10222*	7452*	7452*	5771*	5253	4575*	4013			3424*	3234	10.4
0.0 m			9765*	9765*	7267*	7267*	5607*	5172	4362*	3974			3195*	3195*	10.26
-1.0 m	11032*	11032*	8940*	8940*	6833*	6833*	5275*	5124	3993*	3953			2919*	2919*	10.01
-2.0 m	9133*	9133*	7820*	7820*	6150*	6150*	4737*	4737*	3398*	3398*			2570*	2570*	9.65

STANDARD AND OPTIONAL EQUIPMENT

● Standard ○ Optional

Engine

- Doosan DLo6, Stage IV compliant, SCR, EGR, DOC, water-cooled diesel engine with Wastegate Turbocharger and air-to-air intercooler
- Auto-idle function
- Auto shut-off
- No DPF

Hydraulic system

- Boom and arm flow regeneration
- Swing anti-rebound valves
- Spare ports (valve)
- One-touch power boost function
- Smart Power Control (SPC)
- 2 way auxiliary and PERO piping
- Cylinder cushioning & contamination seals
- Control of auxiliary hydraulic flow and pressure from the display panel

Cab & Interior

- Pressurized, sound-insulated and CabSus mounted cab
- Heated, adjustable air suspension seat with adjustable headrest and armrest
- Air conditioning with climate control
- Pull-up type front window with sun roller blind and removable lower front window
- Sliding left window
- Intermittent upper windshield wiper
- Rain visor
- Rear window defroster switch
- Adjustable PPC wrist control levers for arm, boom, bucket and swing
- Joysticks and pedal provide proportional control of auxiliary lines for attachments
- Adjustable tiltable steering column
- Pedal for auxiliary control 1 & 2 ways
- Jog shuttle switch
- 7" (18 cm) TFT LCD color monitor panel
- Attachment management system with 10 presets
- Engine speed (RPM) control dial
- Automatic travel speed
- 4 operating modes & 4 working modes
- Electric horn
- Cigarette lighter
- Ceiling light
- Cup holder
- Multiple storage compartments (e.g. document holder under seat)
- Storage area (tools, etc.)
- Hot and cool box
- Flat, spacious, easy-to-clean floor
- Master key
- Anti-theft protection
- 12 V spare power socket
- Serial communication port for laptop PC interface
- Remote radio ON/OFF switch
- Loudspeakers and connections for radio
- MP3/USB radio or MP3/USB radio with CD player

Safety

- Boom and arm cylinder safety valves
- Overload warning device
- Large guard rails on upper structure and steps
- Rotating beacon
- Rear & side-view camera
- Punched metal anti-slip plates
- Hydraulic safety lock lever
- Safety glass
- Hammer for emergency escape
- Right and left rear-view mirrors
- Lockable fuel cap and covers
- Battery cut-off switch
- Engine restart prevention system
- Parking brake
- Work lights (2 front frame, 4 front cab-mounted, 2 rear cab-mounted, 2 boom-mounted and 1 rear side)
- Emergency engine stop switch and hydraulic pump control switch
- FOGS cab - top and front cab guards (ISO 10262)
- Front window upper and lower guards

Other

- DX230WMH-5: 6100 mm boom – 4200 mm arm – 4000 kg counterweight
- DX250WMH-5: 6500 mm boom – 4500 mm arm – 5200 kg counterweight
- "Doosan Connect" Telematic system
- Auto shut-off fuel filler pump
- Double element air cleaner and pre-filtered Turbo dust separator
- Fuel pre-filter with water separator sensor
- Dust screen for radiator/oil cooler
- Self-diagnostic function
- Alternator (24 V, 80 A) - Battery (2 × 12 V, 150 Ah)
- Powershift 2-speed transmission + creep mode
- Remote greasing for swing circle and work group pivot points
- Guards for work lights
- Floating boom
- Air compressor
- Arm 4000 mm straight
- Grapples and magnet
- Quick coupler piping for straight arm
- Additional filter for breaker piping
- Double pump flow
- Alarm for travel & swing

Undercarriage

- Double tires 10.00-20-16PR
- Front axle oscillation lock modes (On/Off/Auto)
- Piston rod protection of stabilizer cylinders
- Lockable tool box (left side)
- Rear & front chain tightening eyes
- Wide axle 2750 mm
- 4 independent stabilizers with cylinder protection
- Lockable tool box (right side)
- Solid tire 10.00-20

DOOSAN CONNECT

**WORK EFFICIENCY
MANAGEMENT**

**JOB SITE
MANAGEMENT**

**PROACTIVE
SERVICE**

**PREVENTIVE
MAINTENANCE**

OPERATION TREND

Total operation hours and operation hours by mode

FUEL EFFICIENCY*

Fuel level and fuel consumption

LOCATION

GPS and geo-fence

REPORTS

Operation report & utilization

WARNING & ALERT

Detect machine warnings, antenna disconnection, and geo/time fence

FILTER & OIL MANAGEMENT

Preventive maintenance by item replacement cycle

TELEMATICS TERMINAL

Terminal device is installed and connected to a machine to get machine data.

TELECOMMUNICATION

Doosan provides dual-mode (Mobile, Satellite) communication to maximize communication coverage.

DOOSANCONNECT WEB

Users can monitor machine status from DoosanCONNECT Web.

*Functions may not be applied to all models. Please contact your sales representative for more information on this feature.

DOOSAN GROUP – BUILDING YOUR TOMORROW TODAY

BE PART OF THE GREAT DOOSAN FAMILY

Founded in 1896, Doosan Group is the oldest company in Korea. Rapidly adapting to the changing global environment, it is one of the fastest growing companies in the world.

AFFILIATES

Doosan is making efforts to improve the foundation for life. Doosan can be found in various fields, ranging from the entire infrastructure support business that includes industrial facilities, machinery, equipment, and construction, to the consumer goods business.

Infrastructure Support Business

Doosan Heavy Industries & Construction
 Doosan Infracore
 Doosan Bobcat
 Doosan Engineering & Construction
 Doosan Mecatec
 Doosan Robotics
 Doosan Mobility Innovation
 Doosan Solus
 Doosan Fuel Cell

Holding Company

Doosan Electronics
 Doosan Corporation Mottrol
 Doosan Bio
 Doosan Corporation Industrial Vehicle
 Doosan Digital Innovation
 Doosan Corporation Distribution

Customer & Services

Oricom
 Hancomm
 Doosan Magazines
 Doosan Bears
 Doosan Cuvex
 Neoplux

39400

Doosan Group employees in
 36 countries worldwide



DOOSAN INFRACORE – MANUFACTURING CONSTRUCTION EQUIPMENT FOR OVER 40 YEARS

Doosan Infracore's construction equipment includes crawler and wheeled excavators, mini excavators, wheel loaders and articulated dump-trucks, and diverse attachments as well as diesel and gas engines. With No. 1 market share in Korea, Doosan Infracore is emerging as a global leader in construction equipment manufacturing.

EXPERIENCE THE DOOSAN PRODUCT RANGE!



GLOBAL NETWORK

A truly global player in every respect, we have large-scale factories, sales subsidiaries and dealers all over the world.

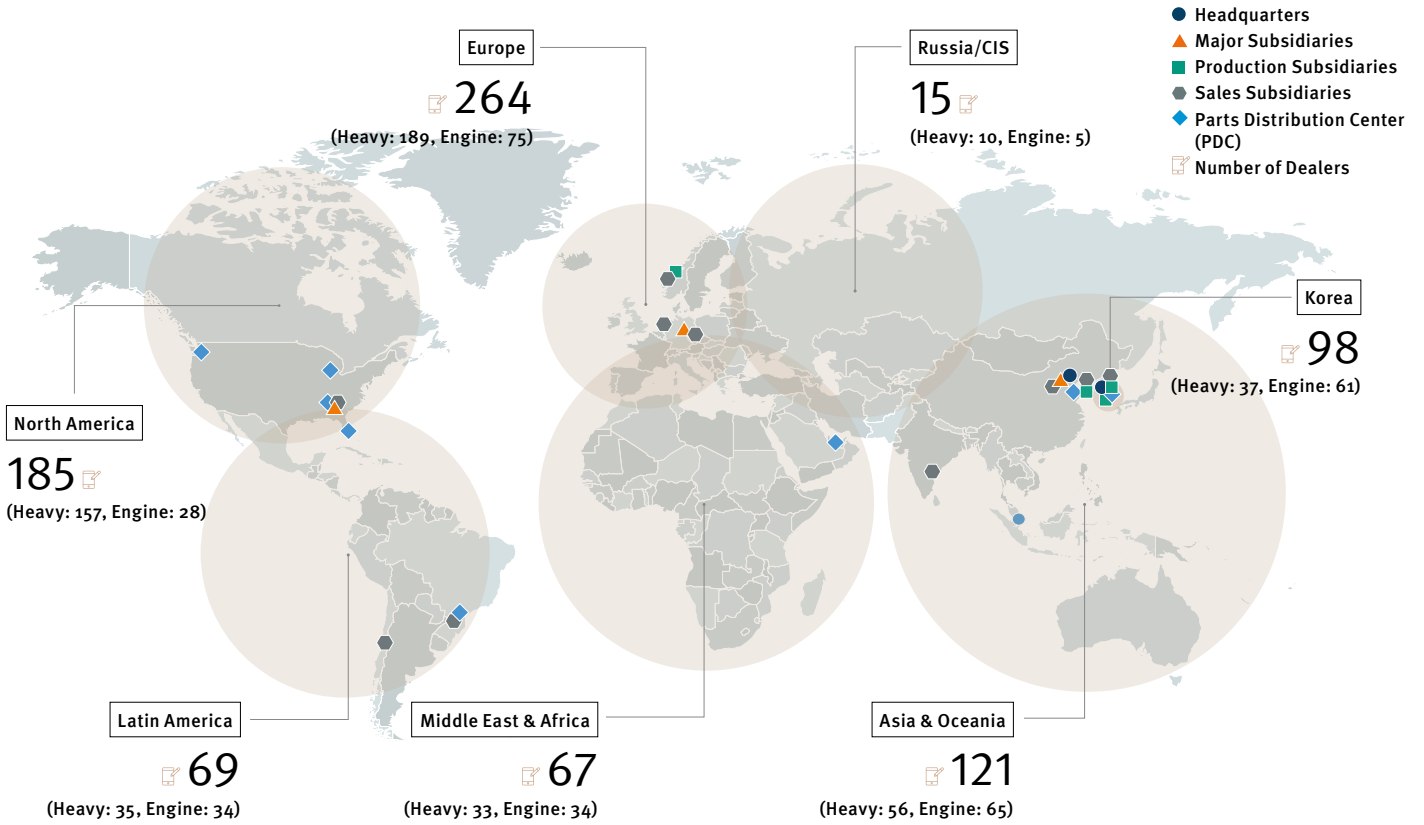

FROM MACHINE MANUFACTURER... TO FULL SOLUTION PROVIDER

Ask your dealer for a full range of services designed especially for you.



CONCEPT-X

Doosan Infracore is not simply adopting digital technology but is seeking to revolutionize the construction machinery industry.

Concept-X is a solution based on technology optimized for future construction sites, such as automated construction site surveying tasks using drones, unmanned automation of equipment, and remote control based on 5G communication.

Powered by **Innovation**

DOOSAN